

SEALING OF VACUUM CLEANERS



A vacuum cleaner is only as good as its seal

Sealing, bonding and potting systems for high-quality household appliances such as vacuum cleaners have to satisfy a wide range of requirements. These make a decisive contribution to user satisfaction through functionality and safety.

As a rule, in a commercial vacuum cleaner, the air that is drawn in is fed directly into the air-permeable dust bag. This filters the air and collects dust at the same time. Bags made of multi-layer filter paper or non-woven bags are commonly used. The smallest particles are separated from the air by the electrostatic attraction of the fibers. The finer the paper filters or synthetic fibers, the greater the specific surface area and the better the separation effect.

After the dust bag, the air flows through a HEPA filter which separates even finer dust. The filter must have a secure filter seat to ensure that the intake air will not flow past the filter due to leakage thus releasing dust residues unfiltered into the room air. However, even the best fine dust filter cannot prevent this if the filter seat leaks. With the polyurethane-based FERMAPOR K31 foam gaskets, component tolerances are compensated for during sealing and therefore an optimally tight filter seat is achieved.

Are you looking for an automated system solution to seal vacuums, consisting of a sealing material, dosing system and process automation system from a single source?

Leading vacuum cleaner manufacturers have relied on our Formed-In-Place-Foam-Gasket (FIPFG) sealing technology and wide range of innovative sealing foams for many years. The optimally coordinated material and machine systems ensure a consistent foam application. These systems are supported by systematic sensor-based process monitoring and contour robots for precise and efficient sealing of vacuum cleaner housings and HEPA filter frames. Our FERMAPOR adhesive sealants are used for bonding the filters in the filter frames.

Do you need an automation system that adapts to your production requirements?

The modular design of our mixing and dosing systems with their peripheral interfaces allows flexible use with excellent integration into existing production concepts. Our CNC-controlled mixing and dosing systems offer high levels of repeatability and dosing accuracy and are highly efficient.

Our solutions offer you exactly the levels of durability, quality and reliability that your customers expect from your products.



Bespoke sealing solution for vacuum cleaners

Contour-accurate and seamless sealing of vacuum cleaner housings with polyurethane foam

The reference material presented here, FERMAPOR K31-A-4025-1 and B-4 (B component), is a room-temperature curing 2-component polyurethane foam for sealing vacuum cleaner housings. The polyurethane sealing foam has already proven itself in use by leading appliance manufacturers for many years. It is applied directly to the component using FIPFG (Formed-In-Place-Foam-Gasket) technology and our fully automated dosing machines, very precisely, safely and efficiently. Due to the chemical reaction of the FERMAPOR K31 material components, good adhesion to the component is usually achieved.

Alternatively, we can also adapt our FERMAPOR K31 polyurethane sealing foams to your specific requirements. Influencing factors include pot life until start of foaming, curing time, and the viscosity, hardness and adhesion properties. Thanks to a mixed-cell foam structure, the closing forces when installing the foam gasket are low.

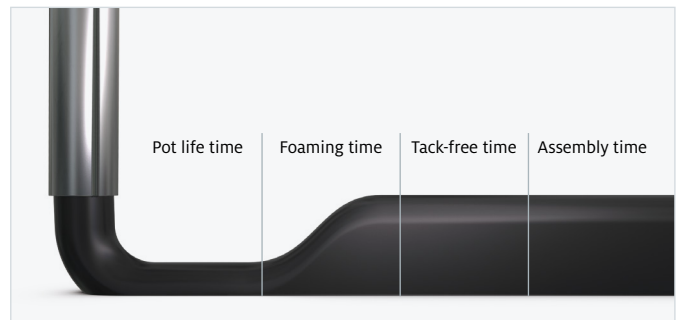

The different reaction phases of the sealing foam in the chronological sequence

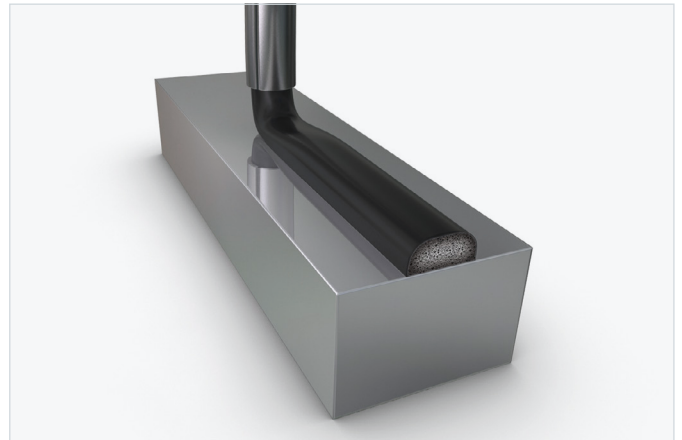

FERMAPOR K31-	A-4025-1 B-4
Mixing ratio	3.7 : 1
Pot life time	32 sec.
Tack-free time	5 min.
Viscosity of the A component	25,000 mPas
Density of the foam	0.2 g/cm ³
Hardness (Shore 00)	38
Temperature resistance	from -40 to +80 °C
Pretreatment	Plasma, Corona, Primer



Cross-section of a polyurethane foam bead – uncompressed



Cross-section of a polyurethane foam bead with 50% compression

The FERMAPOR K31 foam gasket compensates for component tolerances during sealing. It has excellent long-term behavior and good shape recovery characteristics of the compressed foam after releasing the gasket, even after years. This allows frequent opening and re-closing of the housing flap to change the dust bag while maintaining the sealing effect of the foam gasket.

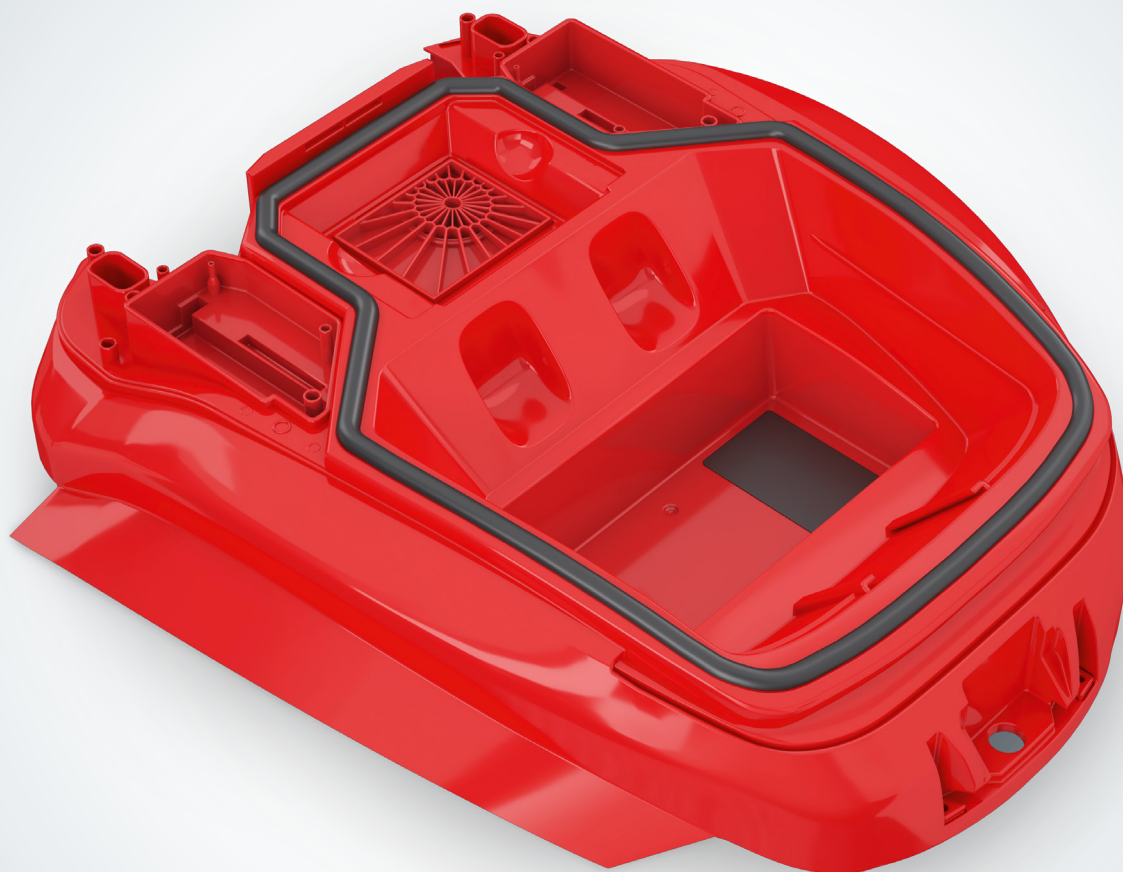

Seamless PU foam sealing of the vacuum cleaner housing

Flexible and fully automatic – fully in line with your requirements

DM 502 mixing and dosing system with 3-axis linear robot for sealing vacuum cleaner housings with polyurethane foam

The reference configuration shown here for true-to-contour application of FERMAPOR K31 2-component polyurethane sealing foam in the groove contour of the vacuum cleaner housing consists of the DM 502 mixing and dosing system with the LR-HD 3-axis linear robot and the WT 1-LEVEL shuttle table. Parts are picked up and processed in continuous shuttle mode in one plane.

The refilling stations of the modular DM 502 system periphery are used for material-specific preparation of the implemented material systems – without contamination by the products to be filled. Equipping the refilling station with a pneumatic lift for the agitator offers more operating convenience and higher occupational and system safety. In addition, agitators stir the materials so that their consistency is homogeneous before they are put into service. A fully automatic production process is only possible if the material pressure vessels are continuously supplied with material by the refilling stations. Capacitive sensors on the material pressure vessels monitor the filling level and control the refilling process. This means that the production process is not interrupted in the event of a material change.

The highly dynamic LR-HD 3-axis linear robot or alternatively the highly efficient LR-HE plus are responsible for the very precise and repeatable guidance of the MK 800 PRO precision mixing head over the component. The mixing head automatically applies the polyurethane foam to the pre-programmed contour with a high degree of accuracy in terms of dosing and repetition. After the dosing cycle, the coupling point of the foam gasket closes seamlessly and is therefore almost invisible. The applied material foams, expanding to several times its original volume, and forms an elastic soft foam gasket with the desired foam hardness at room temperature.

As process experts, we support you with tailored advice for the automation of your manufacturing processes. In all solutions, our main focus is on extremely reliable plant engineering, minimized maintenance times and consistent dosing quality. Thanks to the automatic logging of dosing program data, all process data can be traced and evaluated by the machine operator via the CONTROL 2 operating panel while production is running.



MK 800 PRO precision mixing head
with high-pressure water rinsing



Optionally available: **CONTROL 2 touchscreen operating panel (21.5")**
for operating the dosing system



WT 1-LEVEL shuttle/sliding table
Two pick-up plates operating in shuttle mode in one plane

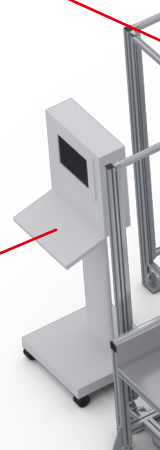

Highly dynamic **LR-HD 3-axis linear robot** for precise guidance of mixing heads for the application of polymer reaction materials. The rack-and-pinion drive with high stiffness and acceleration enables dynamic application speeds.



Optional: Highly efficient **LR-HE plus 3-axis linear robot** for precise guidance of mixing heads for the application of polymer reaction materials. The Omega toothed belt drive enables high application speeds for components with medium and large radii.



Optional: Automatic **SUPPLY TAB drum refilling station** for low-viscosity products, e.g. isocyanate (**B component**)



Optional: Automatic **ELEVATOR drum refilling station** for the **A component** with pneumatic lift and agitator

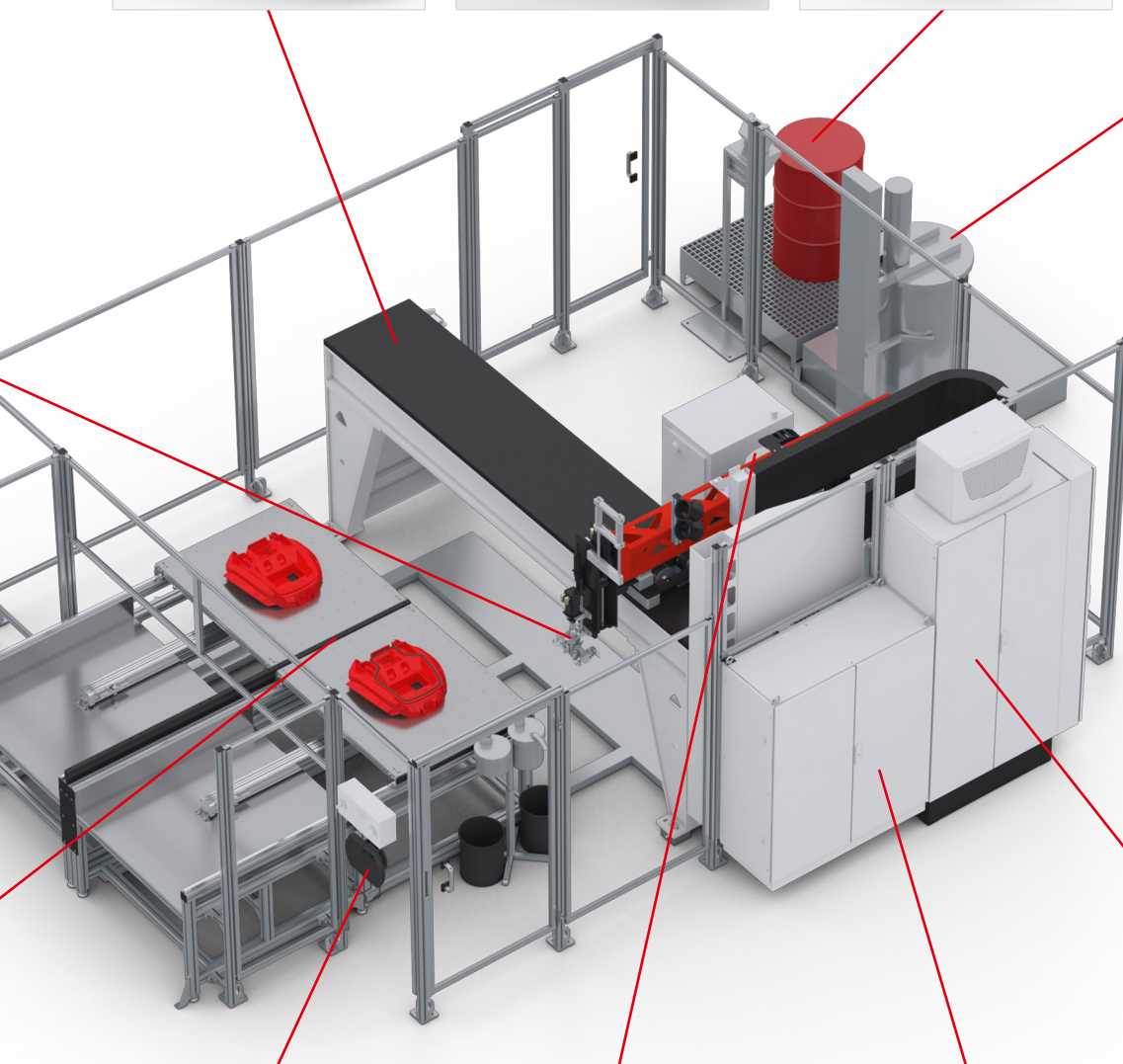

The multifunctional **MP 2 mobile panel** (10.1" WXGA TFT) enables convenient operation of the dosing system.



Separately installed **material pressure tanks** (24 l or 44 l, single-walled or double-walled) with minimum level sensors, on a grating platform with adjustable leveling feet and drip tray

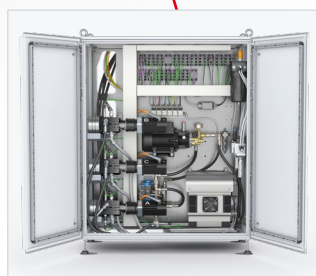

The **dosing machine cabinet** contains the components of the dosing periphery, e.g. the dosing pumps.



The control electronics, safety engineering and industrial PC are installed in the **control cabinet**.

Customized sealing solution for vacuum cleaner HEPA filters

Sealing of filter frames with sealing foam and frame bonding of filter packs with adhesive sealant

The reference materials presented here are polyurethane-based, room-temperature curing 2-component sealing foam and adhesive sealant systems that have already proven their value through many years of use by leading filter manufacturers. They are applied directly to the component using FIPFG (Formed-In-Place-Foam-Gasket) technology and our fully automated dosing machines, very precisely, safely and efficiently.

FERMAPOR K31-A-4025-1 and B-4 (B component) polyurethane sealing foam is used for sealing the filter frames of HEPA filters for vacuum cleaners. The adhesive sealant FERMADUR A-196-9-VP1 and B-N (B component) is available for bonding the filter packs in the filter frames. Whenever possible, we can also customize our material systems to meet your specific requirements. Influencing factors include pot life until start of foaming, curing time, and the viscosity, hardness and adhesion properties.

The FERMAPOR K31 foam gasket has excellent shape recovery characteristics and shows excellent long-term behavior even after years of continuous use due to compression of the foam cell structure. Potential component tolerances of the filter frame are compensated for when sealing with the soft foam gasket. The low closing forces thanks to mixed-cell foam structure facilitate installation of the foamed HEPA filter frame in the vacuum cleaner.

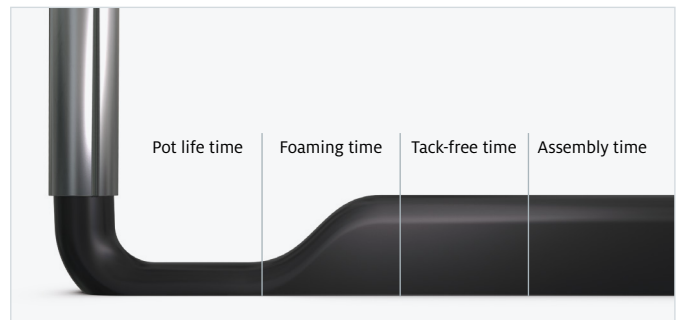

The different reaction phases of the sealing foam in the chronological sequence

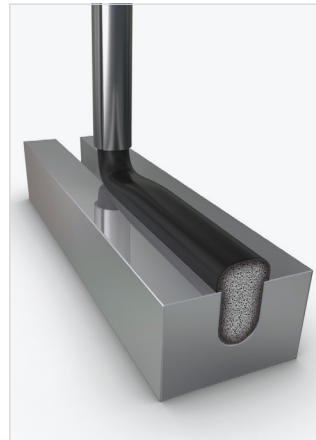

FERMAPOR K31 PU foam gasket in the groove

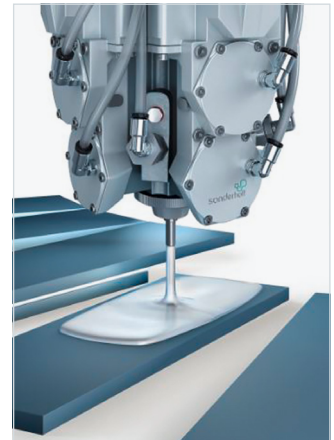

FERMADUR adhesive sealant for frame bonding of filter packs

	FERMAPOR K31-A-4025-1 FERMAPOR K31-B-4	FERMADUR A-196-9-VP1 FERMADUR B-N
Mixing ratio	3.7 : 1	2.8 : 1
Pot life time	32 sec.	67 sec.
Tack-free time	5 min.	3 min.
Viscosity of the A component	25,000 mPas	6,100 mPas
Density of the foam	0.2 g/cm ³	1.27 g/cm ³
Hardness	38 (Shore 00)	87 (Shore A)
Temperature resistance	from -40 to +80 °C	from -40 to +80 °C
Pretreatment	Plasma, Corona, Primer	Plasma, Corona, Primer



Cross-section of a polyurethane foam bead in groove uncompressed



Cross-section of a polyurethane foam bead in the groove and compressed to approx. 50%

In addition to the compact FERMADUR adhesive sealants, we also offer foamed filter adhesives with a lower density for bonding the filter packs in the filter frames. The amount of adhesive per filter can therefore be reduced by up to 50 percent. The lower weight also ensures lighter and therefore easier parts handling. Both save money while still satisfying the requirements for high-quality filter bonding.

The good flow properties of FERMADUR adhesive sealants ensure they are applied to the entire surface on the inside of the filter frame and the filter pack. The filter pack positioned in the filter frame is therefore optimally bonded and sealed on all sides.

Sealing foams and adhesive sealants are cured at room temperature, saving the expense of the annealing oven required by other methods.



Dosing application of PU foam using a precision mixing head for sealing the filter frames of HEPA filters for vacuum cleaners

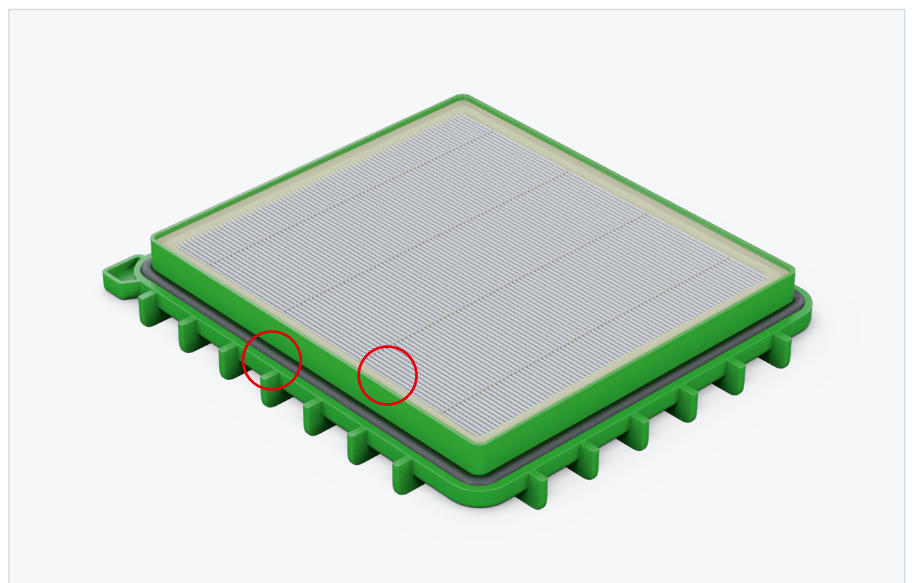

PU foam sealing of filter frames and frame bonding of filter packs with PU adhesive sealant

Flexible and fully automatic – fully in line with your requirements

DM 503 mixing and dosing system for 3 components for simultaneous sealing of filter frames and bonding of HEPA filter packs

The reference configuration shown here for sealing filter frames with polyurethane sealing foam and bonding filter packs in the filter frames with adhesive sealant consists of the DM 503 mixing and dosing system for 3 components with the LR-HD 3-axis linear robot and the WT 1-LEVEL shuttle table. Parts are picked up and processed in continuous shuttle mode in one plane. Alternatively, we offer the WT 2-LEVEL shuttle table with pick-up plates operating in shuttle mode, one above the other in two planes. The components are placed either by a machine operator, who can also check the parts for quality, or by a Pick & Place Robot. In the latter case, an optionally installed camera system could perform quality control of the parts. The advantage of this system configuration in which 3 material components are used is that both seal foaming and bonding can be carried out with the same dosing system.

The highly dynamic LR-HD 3-axis linear robot or, alternatively, the highly efficient LR-HE plus ensures contour-accurate guidance of the MK 800 PRO precision mixing head over the component. In this process, the FERMAPOR K31 sealing foams are applied to the pre-programmed contour of the filter frame fully automatically and with high dosing accuracy.

After the dosing cycle, the coupling point of the foam gasket closes seamlessly and is therefore almost invisible. The applied material expands to several times its volume and forms an elastic soft foam gasket at room temperature with the desired foam hardness, which usually achieves excellent adhesion to the component.

The 2-component FERMADUR adhesive sealants are applied via the mixing head to the outer edges of the filter pack and simultaneously to the inner sides of the filter frame in a process-reliable manner. This creates a full-surface bond, with which the filter pack is optimally bonded and sealed on all sides in the frame.

Our fail-safe mixing and dosing systems can be operated easily and intuitively without the need for extensive training. Thanks to the automatic logging of dosing program data, all process data can be traced and evaluated by the machine operator via the CONTROL 2 operating panel while production is running. As process experts, we support you with tailored advice for the automation of your manufacturing processes.



MK 800 PRO precision mixing head with high-pressure water rinsing



Optionally available: **CONTROL 2 touchscreen operating panel (21.5")** for operating the dosing system



Optional: **WT 2-LEVEL shuttle / sliding table** Two pick-up plates operating in shuttle mode in two planes



WT 1-LEVEL shuttle / sliding table Two pick-up plates operating in shuttle mode in one plane



Highly dynamic **LR-HD 3-axis linear robot** for precise guidance of mixing heads for the application of polymer reaction materials. The rack-and-pinion drive with high stiffness and acceleration enables dynamic application speeds.

Optional: Highly efficient **LR-HE plus 3-axis linear robot** for precise guidance of mixing heads for the application of polymer reaction materials. The Omega toothed belt drive enables high application speeds for components with medium and large radii.

Optional: Automatic **SUPPLY TAB drum refilling station** for low-viscosity products, e.g. isocyanate (**B component**)

Optional: Automatic **ELEVATOR drum refilling station** for the **A component** with pneumatic lift and agitator

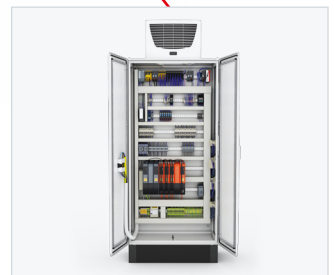
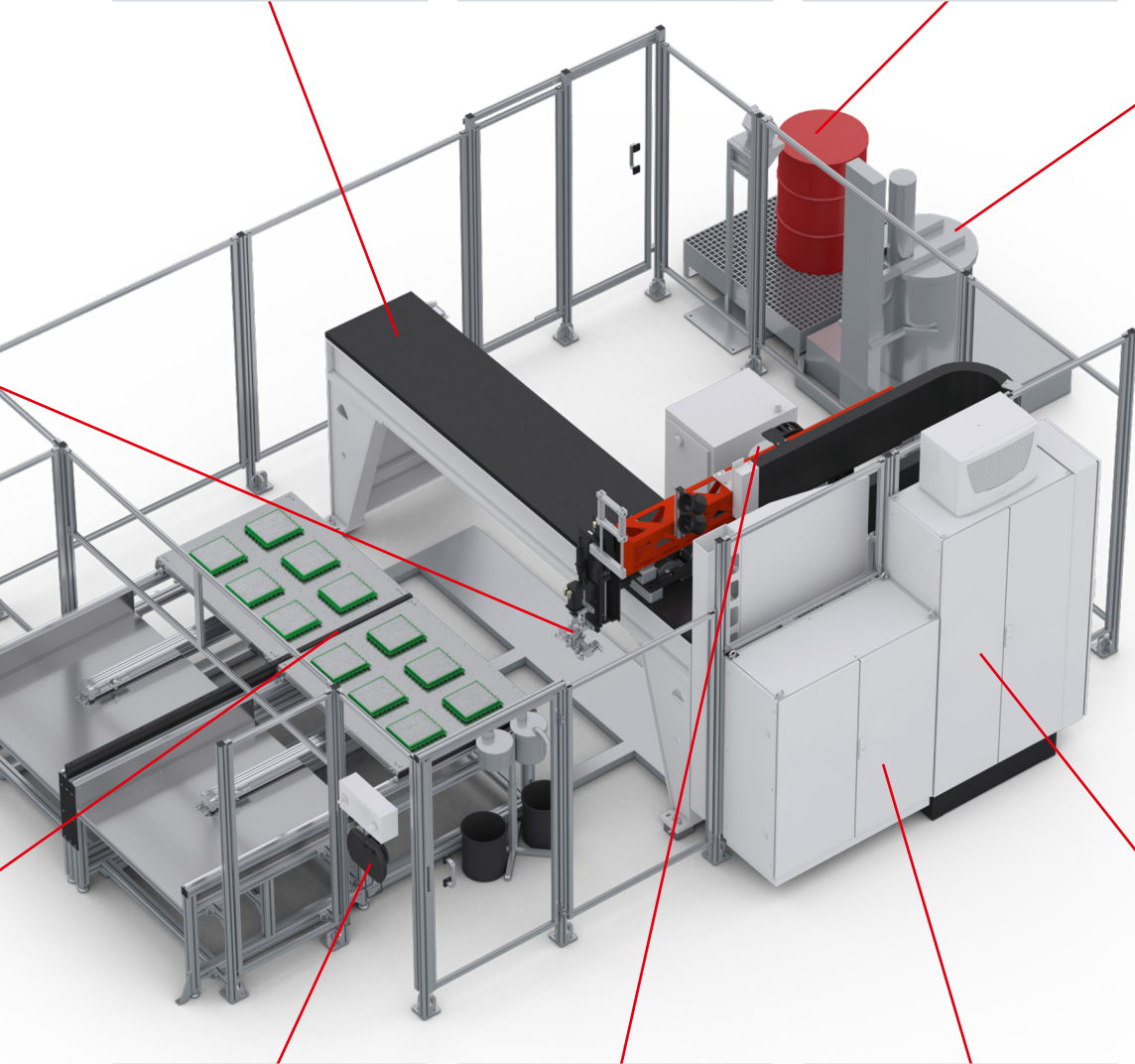
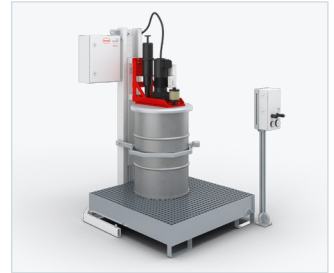

The multifunctional **MP 2 mobile panel** (10.1" WXGA TFT) enables convenient operation of the dosing system.

Separately installed **material pressure tanks** (24 l or 44 l, single-walled or double-walled) with minimum level sensors, on a grating platform with adjustable leveling feet and drip tray

The **dosing machine cabinet** contains the components of the dosing periphery, e.g. the dosing pumps.

The control electronics, safety engineering and industrial PC are installed in the **control cabinet**.

A close-up photograph of a grey industrial machine head, likely a robotic dispenser, with the 'sonderhoff' logo in grey and a teal-colored stylized logo above it. A red, flexible, curved tube is being dispensed from the machine's nozzle. The machine has several screws and a textured grey ring around the nozzle.

sonderhoff

This is why you should use the FIPFG technology
in your production process

- +** **Advantages of the Formed-In-Place Foam Gasket Technology**
- › Sealing standard in many industrial sectors
 - › Highly accurate material application controlled by contour robots
 - › Processing and full curing at room temperature
 - › Perfect coordination of the material system and dosing system
 - › Suitable for 2D and complex 3D part geometries
 - › More efficient use of materials compared to punched seals
 - › Cheaper compared to 2-C injection molding, as there are no tooling costs
 - › High degree of future viability, due to suitability for use in a wide variety of industries & applications



Advantages of our mixing and dosing machines

- › Combination of processes (bonding, foaming, caulking, potting)
- › High flexibility of the dosing system
- › Simple, intuitive operation
- › Automatic material preparation incl. handling
- › High dosing and repeat accuracy
- › Short machine downtimes and cycle times
- › Fine-cell foam structure due to dynamic mixing
- › Reproducible foam quality
- › Ecological high-pressure water rinsing
- › Easy maintenance



Advantages of our FIPFG foam gaskets

- › More cost-effective than compact systems due to lower foam density
- › Seamless seal / hardly visible coupling point
- › Compensation of component tolerances
- › Good resilience
- › Multiple compression and release processes possible
- › Broad range of properties / wide variety of recipes
- › Individually adaptable recipes
- › Good form fit to the component contour
- › Resistant to moisture, dust, temperature & media
- › Flame-retardant according to UL 94
- › IP classes up to IP 68 or NEMA 4 to 6 and NEMA 12
- › Special PU foam with low VOC emissions
- › Very fast reacting PU foam (Fast-Cure)

Perfectly coordinated solutions of material, machine and contract manufacturing

With its Sonderhoff brand, Henkel has not only acquired many years of experience in the manufacture of tailor-made two-component sealing systems and mixing and dosing machines, but also as a process expert for application-specific material application using the FIPFG (Formed-In-Place-Foam-Gasket) technology.

With the Sonderhoff portfolio, we offer you the advantages of a system provider from a single source and the solutions to meet your technical and commercial challenges.

With the dosing technology that is tailored to our sealing foams, we ensure efficient production processes in accordance with the requirements of fully automated series production.

If you would like to take advantage of all the benefits of the FIPFG technology for your production in a flexible, fast, uncomplicated manner and without having to make your own acquisition investments, we can provide expert sealing for your components at one of our contract manufacturing sites worldwide. There, the spectrum ranges from the sampling of prototypes and small batch series to production scale manufacturing.

The choice is yours! You can either decide in favor of our all-inclusive package, consisting of material, machine and contract manufacturing, supported by application advice, sampling and training or you can choose the individual solutions that suit you best. We combine our products and services from a single source in such a way that you receive the optimum solution for your requirements profile.

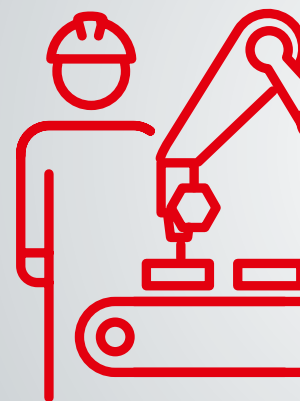

MANUFACT

Flexibility & Precision

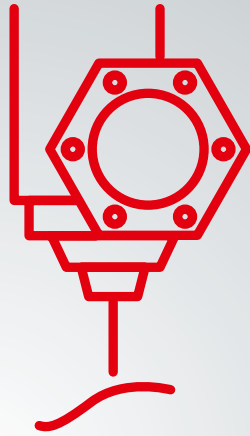

EQUIPMENT

Automation Solutions

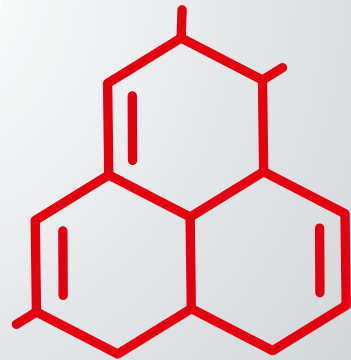

MATERIALS



URING

Customer-specific solutions – worldwide and for many industries

The Henkel specialists for the Sonderhoff portfolio
are available globally

KOLO, POLAND
External Subcontracting Location

DÜSSELDORF, GERMANY
Center of Expertise

ELGIN, ILLINOIS, USA
Regional Hub

RICHMOND (KANSAS CITY), USA
Regional Hub

DORNBIRN, AUSTRIA
Center of Expertise

BARCELONA, SPAIN
External Subcontracting Location

OGGIONO, ITALY
Regional Hub

INCHEON, KOREA
External Subcontracting Location

SHANGHAI, CHINA
Regional Hub

PUNE, INDIA
Regional Hub

PUNE, INDIA
External Subcontracting Location

SÃO PAULO, BRAZIL
External Subcontracting Location

Global presence



Every year, more than 300 million seals are manufactured in more than 50 countries using products from Henkel's Sonderhoff portfolio. At our Centers of Expertise and Regional Hubs, our specialists offer application engineering advice, e.g. selecting a suitable material system and sampling of your components, as well as project management for dosing systems and automation. You will receive training from us on how to use the FIPFG technology and we will support you with the selection of spare parts and a regular service offering. Furthermore, we will be pleased to take over parts of your production for you – from small to large series – at our subcontracting locations.

Sales staff at all other Henkel locations worldwide will also be happy to answer any questions and provide you with further information on our sealing, bonding, and potting solutions. We look forward to hearing from you.



Henkel Corporation

One Henkel Way
Rocky Hill, CT 06067
United States
Tel.: +1 860 571 5100
Fax: +1 860 571 5465

www.henkel-northamerica.com

www.henkel-adhesives.com

www.sonderhoff.us

Get in contact with us



The data contained herein are furnished for information only and are believed to be reliable. We cannot assume responsibility for the results obtained by others over whose methods we have no control. It is the user's responsibility to determine suitability for the user's purpose of any production methods mentioned herein and to adopt such precautions as may be advisable for the protection of property and of persons against any hazards that may be involved in the handling and use thereof. In light of the foregoing, Henkel Corporation specifically disclaims all warranties expressed or implied, including warranties of merchantability or fitness for a particular purpose, arising from sale or use of Henkel Corporation's products. Henkel Corporation specifically disclaims any liability for consequential or incidental damages of any kind, including lost profits. The discussion herein of various processes or compositions is not to be interpreted as representation that they are free from domination of patents owned by others or as a license under any Henkel Corporation patents that may cover such processes or compositions. We recommend that each prospective user test his proposed application before repetitive use, using this data as a guide. This product may be covered by one or more United States or foreign patents or patent applications. The information, product features and pictures contained in this brochure are intended exclusively as a technical guide. Henkel is not responsible for any technical changes or print / typographical errors. Reproduction in whole or in part is prohibited without the prior written consent of Henkel AG & Co. KGaA. Except as otherwise noted, all marks used are trademarks and / or registered trademarks of Henkel and its affiliates in Germany, the U.S., and elsewhere.

© 8.2024 Henkel AG & Co. KGaA. All rights reserved