

SEALING OF LOUDSPEAKERS



Vibration-damping noise protection for sophisticated acoustics

Today, cars are concert halls on wheels due to the increased number of speakers. Just to cover the entire frequency range from bass, midrange to treble for the human ear, at least four loudspeakers with a good sound pressure level are needed in the vehicle interior.

For maximum acoustic efficiency, a high-quality amplifier is also required to supply all of the speakers with sufficient power, as well as a subwoofer that is best placed in the trunk. Further requirements include two woofers placed in the doors or footwell, midrange speakers in the upper door area for sound transparency, and tweeters in the A-pillar or dashboard.

Additional speakers are required in order to create a quality hi-fi sound experience for the front and other passengers, as well as elaborate 3D sound experiences. The models of the premium manufacturers have up to 23 speakers. Each of these speakers plays a special role.

So there is quite a lot which comes together in order to create a concert hall experience in the car. To ensure that nothing interferes with a pleasurable listening experience, our sealing and potting solutions dampen the vibrations and annoying noises which occur while driving. These ensure a firm fit of the loudspeakers when they are mounted in the door unit carriers (the so-called AGT door modules) and create a seal against the AGT.

The leading manufacturers of loudspeakers have relied on our Formed-In-Place Foam Gasket (FIPFG) sealing technology and wide range of innovative material systems for many years.

Are you looking for a more efficient way of using materials for sealing your loudspeakers other than with punched seals, as well as a cheaper solution without tooling costs compared to 2-C injection molding?

We will provide you with a perfectly coordinated sealing solution that consists of a sealing foam that satisfies your requirements and a dosing system for high-precision, fully automatic material application that is controlled by contour robots.

Do you require a flexible automation system for sealing your loudspeaker baskets that can be variably adapted to your production conditions?

With our machine solutions, the focus is placed therefore on the extremely flexible use of your dosing system which can be integrated very well into existing production concepts thanks to its modular structure. You are provided with a fail-safe mixing and dosing system that is also very easy and intuitive to operate.



Reliable sealing with optimized material consumption

Polyurethane sealing foams from the FERMAPOR K31 product family are used to seal the plastic loudspeaker baskets installed in the AGT door modules. The foam material which is dosed with our mixing and dosing system is applied to the flat or slightly recessed application surface of the loudspeaker baskets, where it remains stable.

The soft seal that is foamed in place solidifies due to a crosslinking reaction of the polyurethane foam components and is usually tack-free after a few minutes at room temperature. The adjustable degree of softness is advantageous for low installation force when the loudspeakers are incorporated into the AGT door modules.

Due to the mixed-cell foam structure, the polyurethane seal can be compressed evenly and provides a consistently high level of impermeability to moisture when installed. The electrical connections for loudspeakers are therefore protected against corrosion and possible failure as a consequence. Furthermore, the foam gasket acts as protection against rattling by damping the vibrations and noise generated when the vehicle is being driven.

Moreover, thanks to the efficient and precise FIPFG technology, significantly less material is used when the sealing process is carried out using polyurethane foam compared to the punched seals used in the past.

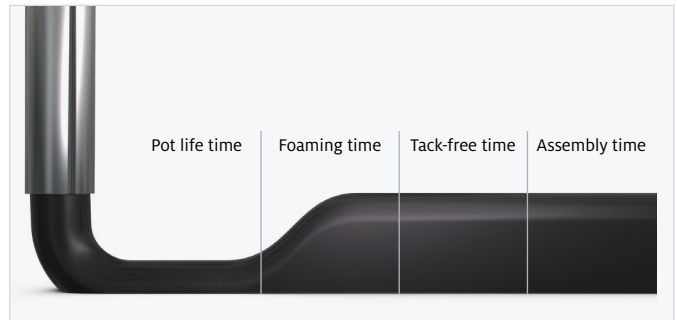

The different reaction phases of the sealing foam in the chronological sequence

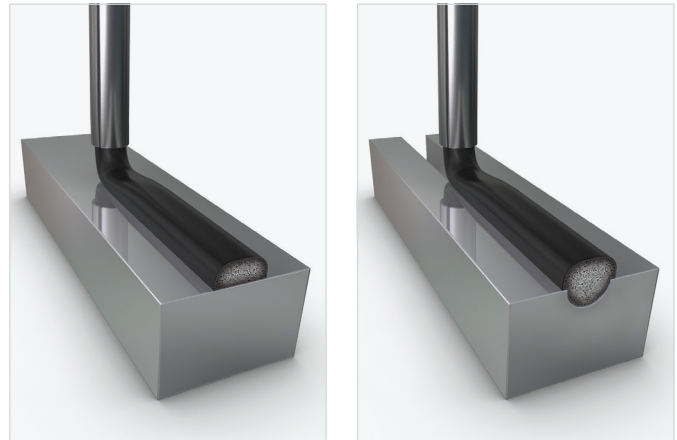

	Loudspeaker
	FERMAPOR K31-A-9285-21-F
	FERMAPOR K31-B-N
Mixing ratio	5.5 : 1
Pot life time	32 sec.
Tack-free time	4 min.
Viscosity of the A component	3,000 mPas
Density	0.23 g/cm ³
Hardness (Shore 00)	43
Temperature resistance	from -40 to +80 °C
Pretreatment	Plasma for e.g. PP and PE



The unpressed polyurethane foam gasket before installation.



Pressing the foam gasket achieves the required degree of tightness achieved in the installed condition.

The excellent resilience of the foam gasket enables the repeated installation and removal of the loudspeaker for maintenance purposes without weakening the sealing effect.

The polyurethane foam used adheres very well to the plastics commonly used for loudspeaker baskets, whereas for adhesion to plastics such as PP or PE, it is often necessary to carry out pretreatment with plasma. For this purpose, we will be pleased to integrate a plasma application unit into your automation system.



Flexible and fully automatic – fully in line with your requirements

DM 502 mixing and dosing system with 3-axis linear robot and a conveyor belt for the feeding of parts

Through our combination of individual material systems, customer-specific mixing and dosing machines and skilled process expertise, we offer solutions to meet your technical and commercial challenges.

We support you with our application engineering expertise from the design phase of your components to fully automated material application using Formed-In-Place Foam Gasket (FIPFG) technology. An important success factor for the efficiency of our overall solution is its optimal integration into your production. As process experts, we promise to provide you with individual advice for the automation of your manufacturing processes. To achieve this, we offer various configuration and equipment options for semi-automatic or fully automatic production systems.

In the illustrated reference configuration of the DM 502 mixing and dosing system, the loudspeaker baskets, which have previously been produced by injection molding, are guided on a transfer belt from the injection molding system under the 3-axis linear robot to the dosing station. The LR-HD 3-axis linear robot takes over the CNC-controlled movement of the precision mixing head above the component with contour accuracy. Before the sealing foam is dosed and applied through the nozzle of the MK 825 PRO precision mixing head, the component contour is provided with surface activation with plasma. This results in better adhesion of the foam gasket.

After the plasma treatment, paste-like polyurethane sealing material is applied automatically to the flat or slightly recessed application surface of the loudspeaker baskets using the FIPFG process with high dosing and repeat accuracy. After the dosing cycle, the coupling point of the foam gasket closes seamlessly and is almost invisible.

The material components of the polyurethane foam used are mixed dynamically and homogeneously in the precision mixing head of the DM 502. The resulting fine-cell foam structure is crucial for low water absorption levels. When installed, the uniform compression of the seamless foam gasket produces a consistently high level of tightness over the entire contour of the loudspeaker basket.



Optionally available: **CONTROL 2 touchscreen operating panel** (21.5") for operating the dosing system

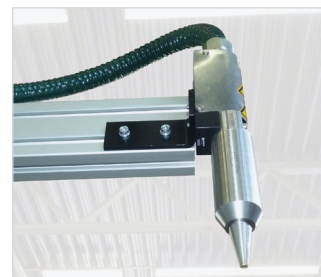

Surface activation through atmospheric plasma to improve adhesion. The **optional plasma nozzle** can be installed either on the back of the Y-axis or parallel to the mixing head with a lifting unit.



Material pressure tanks (24 l or 44 l, single-walled or double-walled) with minimum level sensors, on a grating platform with adjustable leveling feet and drip tray

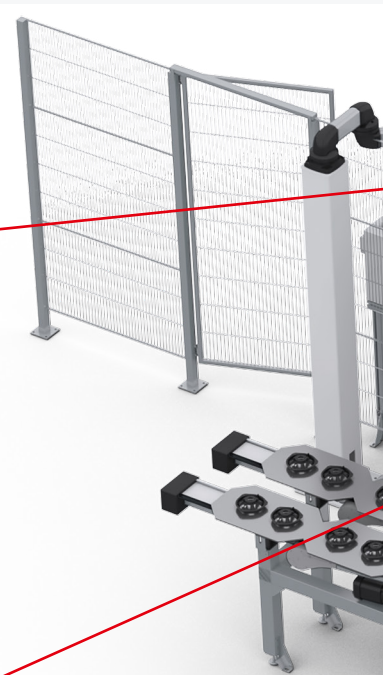

The **dosing machine cabinet** contains the components of the dosing periphery, such as the dosing pumps.

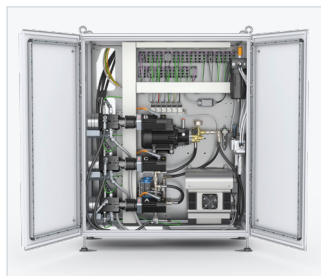

The control electronics, safety engineering and industrial PC are installed in the **control cabinet**.



2-axis mixing head traversing unit for the precise positioning of mixing heads in various locations for the application of polymer reaction materials – optionally available with an electric or pneumatic drive.



The multifunctional **MP 2 mobile panel** (10.1" WXGA TFT) enables convenient operation of the dosing system.

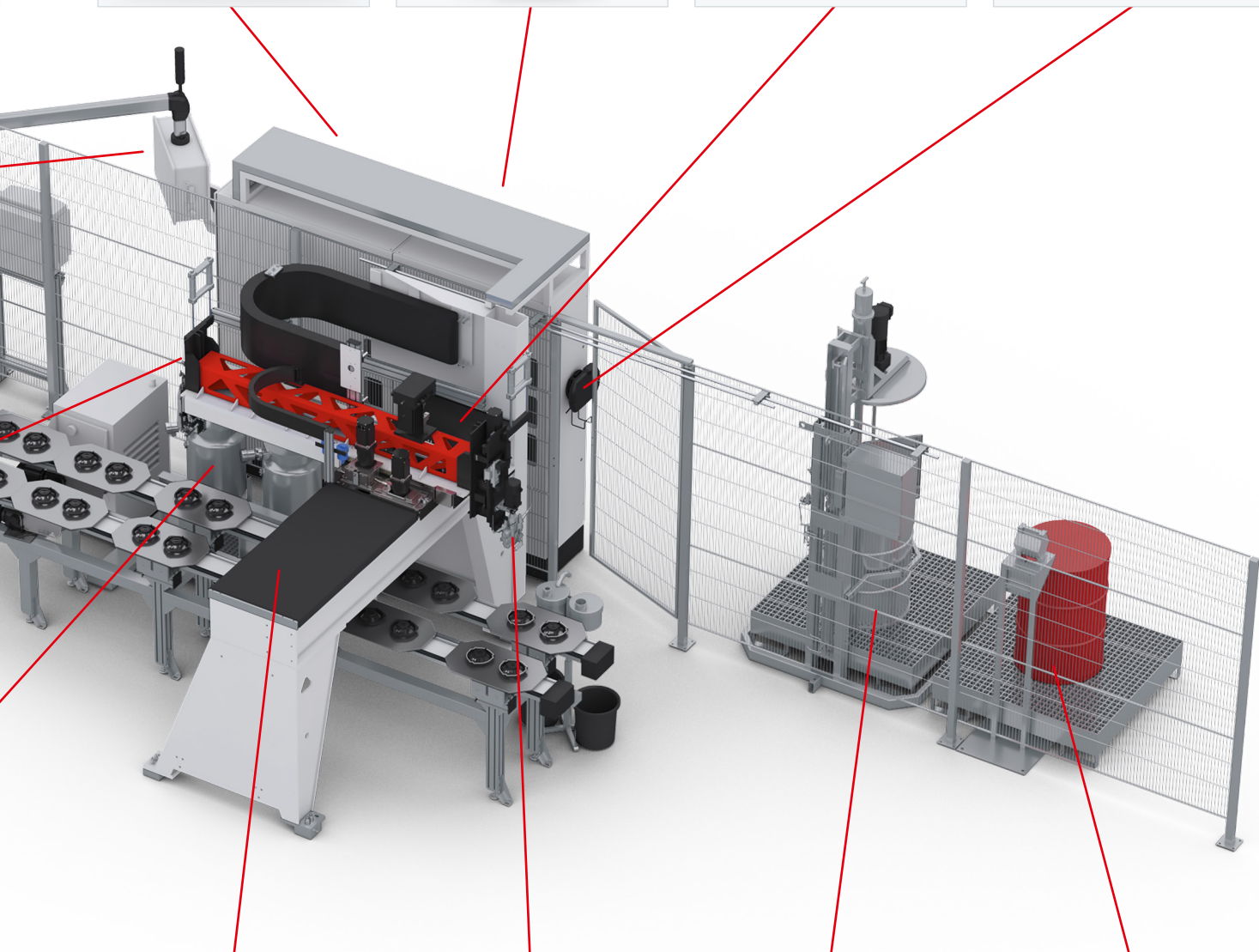

Highly efficient **LR-HD 3-axis linear robot** for precise guidance of mixing heads for the application of polymer reaction materials. The rack and pinion drive with high stiffness and acceleration enables dynamic application speeds.

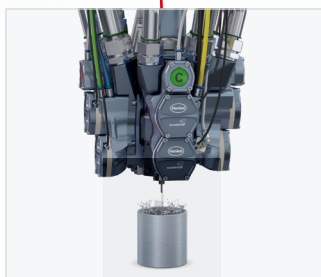

MK 825 PRO precision mixing head with high-pressure water rinsing



Automatic **ELEVATOR drum refilling station** for the **A component** with pneumatic lift and agitator



Automatic **SUPPLY TAP drum refilling station** for low-viscosity products, e.g. isocyanates (**B component**)

An alternative reference configuration

DM 502 mixing and dosing system with 3-axis linear robot and a shuttle table for the parts holder

The alternative reference configuration shown here consists of our DM 502 mixing and dosing system with LR-HE plus 3-axis linear robot and the WT 1-LEVEL shuttle table for the parts holder. The two shuttle tables, working in pendulum mode, enable the workpieces fixed there to be picked up and processed in one level. This means that very short cycle times and continuous operation can be guaranteed.

The placement and positioning of the loudspeaker baskets on the shuttle table top is performed either by a machine operator, who can also check the parts for quality, or by a Pick & Place Robot. In this case, an optionally installed camera or sensor system could carry out the quality control of the parts.

The optional plasma nozzle, CNC-controlled by the LR-HE plus 3-axis linear robot and mounted on the rear of the Y-axis, applies plasma to the component contour for surface activation. This results in better adhesion of the foam gasket.

The polyurethane sealing material is dosed with the CNC-controlled MK 825 PRO precision mixing head and applied with high precision fully automatically to the flat or slightly recessed surface of the speaker basket contour. This FIPFG process ensures high dosing and repeat accuracy. After the dosing cycle, the coupling point of the foam gasket closes seamlessly and is almost invisible.

The material components of the polyurethane foam used are mixed dynamically and homogeneously in the precision mixing head of the DM 502. The resulting fine-cell foam structure is crucial for low water absorption levels. When installed, the uniform compression of the seamless foam gasket produces a consistently high level of tightness over the entire contour of the loudspeaker basket.



MK 825 PRO precision mixing head
with high-pressure water rinsing



Optionally available: **CONTROL 2 touchscreen operating panel** (21.5")
for operating the dosing system



WT 1-LEVEL shuttle / sliding table
Two pick-up plates operating in pendulum mode in one plane

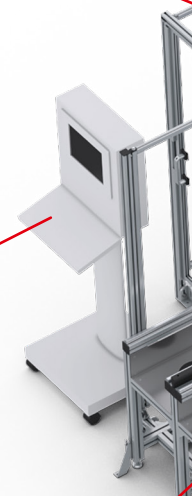

Highly efficient **LR-HE plus 3-axis linear robot** for precise guidance of mixing heads for the application of polymer reaction materials. The Omega toothed belt drive enables high application speeds for components with medium and large radii.



Surface activation through atmospheric plasma to improve adhesion. The **optional plasma nozzle** can be installed either on the back of the Y-axis or parallel to the mixing head with a lifting unit.

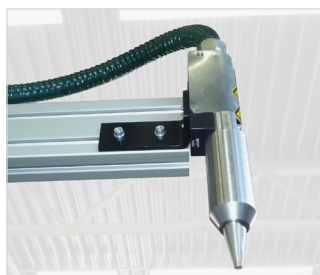

Automatic **SUPPLY TAP drum refilling station** for low-viscosity products, e.g. isocyanates (**B component**)



Automatic **ELEVATOR drum refilling station** for the **A component** with pneumatic lift and agitator

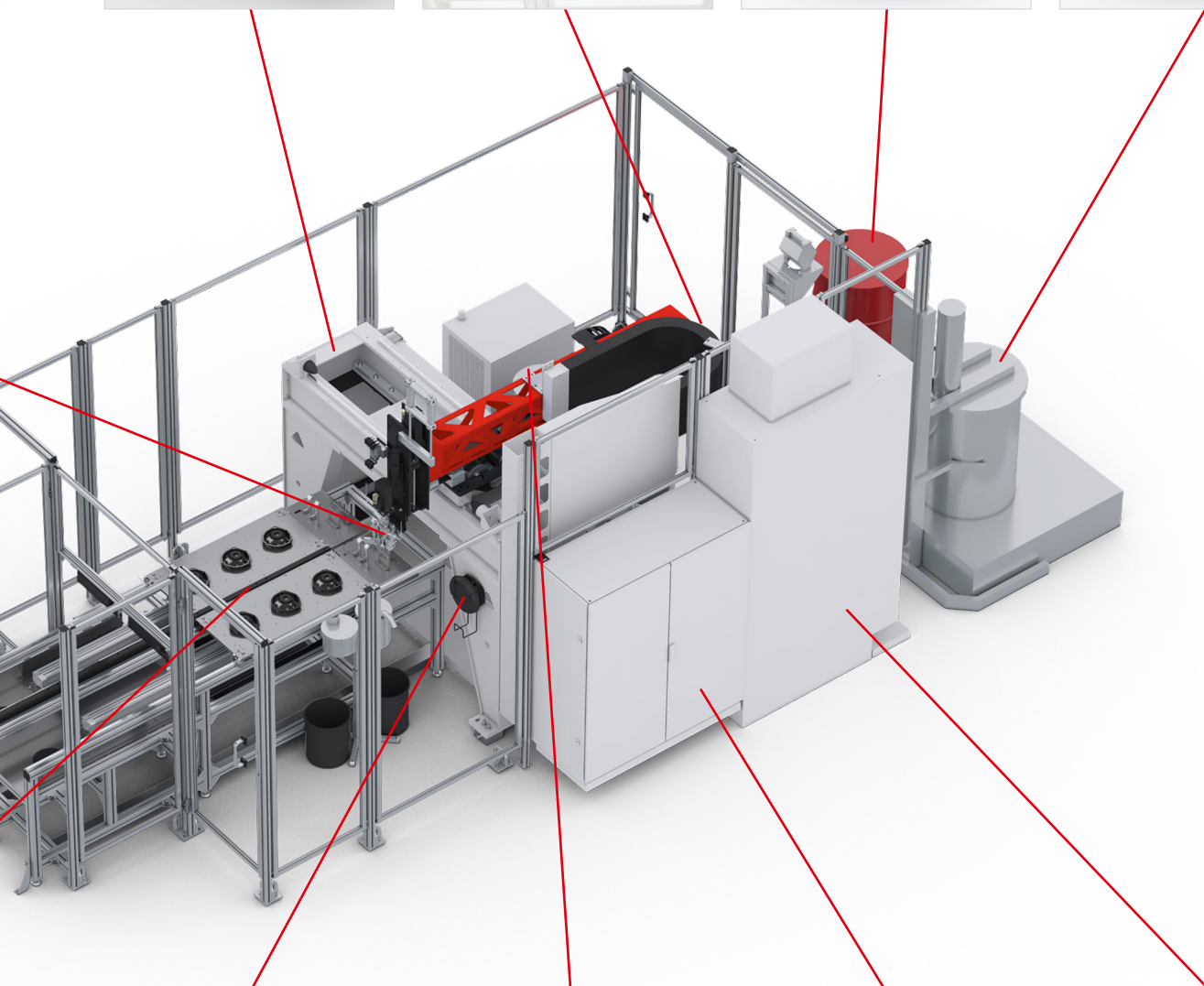

The multifunctional **MP 2 mobile panel** (10.1" WXGA TFT) enables convenient operation of the dosing system.



Material pressure tanks (24 l or 44 l, single-walled or double-walled) with minimum level sensors, on a grating platform with adjustable leveling feet and drip tray

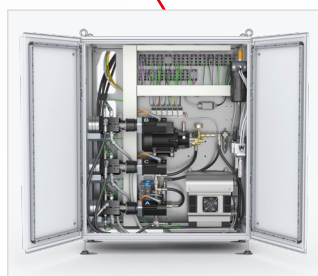

The **dosing machine cabinet** contains the components of the dosing periphery, such as the dosing pumps.



The control electronics, safety engineering and industrial PC are installed in the **control cabinet**.

This is why you should use the FIPFG technology in your production process



Advantages of the Formed-In-Place-Foam-Gasket Technology

- › Sealing standard in many industrial sectors
- › Highly accurate material application controlled by contour robots
- › Processing and full curing at room temperature
- › Harmonized coordination of the material system and dosing system
- › Suitable for 2D and complex 3D part geometries
- › More efficient use of materials compared to punched seals
- › More cost effective compared to 2K injection molding, as there are no tooling costs
- › High degree of future viability, due to solution flexibility in a wide variety of industries & applications



Advantages of our mixing and dosing machines

- › Combination of processes (bonding, foaming, potting)
- › High flexibility of the dosing system
- › Simple, intuitive human interface
- › Automatic material preparation incl. handling
- › High dosing and repeat accuracy
- › Short machine downtimes and cycle times
- › Fine-cell foam structure due to dynamic mixing
- › Reproducible foam quality
- › Ecological high-pressure water rinsing
- › Easy maintenance



Advantages of our FIPFG foam gaskets

- › More cost-effective than compact systems due to lower foam density
- › Seamless seal / low visible coupling point
- › Compensation of component tolerances
- › Excellent resilience after compression
- › Multiple compression and release processes possible
- › Broad range of properties / wide variety of formulations
- › Individually adaptable formulations
- › Good form fit to the component contour
- › Resistant to moisture, dust, temperature & media
- › Flame-retardant according to UL 94
- › IP classes up to IP 68 or NEMA 4 to 6 and NEMA 12
- › Special PU foam with low VOC emissions
- › Very fast reacting PU foam (Fast-Cure)

Perfectly coordinated solutions of material, machine, and contract manufacturing

With its Sonderhoff brand, Henkel has not only acquired many years of experience in the manufacturing of tailor-made 2 component sealing systems and mixing and dosing machines, but also process expertise for very precise material application using the FIPFG (Formed-In-Place-Foam-Gasket) technology.

With the Sonderhoff portfolio, we offer our customers the advantages of a system provider from a single source and the solutions to meet your technical and commercial challenges.

With the dosing technology that is tailored to our sealing foams, we ensure efficient production processes in accordance with the requirements of fully automated series production.

If you would like to take advantage of all the benefits of the FIPFG technology for your production in a flexible, fast, and effective manner, we provide sealing solutions for your components at one of our many contract manufacturing sites worldwide without having to make your own acquisition investments. There, the spectrum ranges from the sampling of prototypes and small batch series to production scale manufacturing.

The choice is yours! You can either decide in favor of our all-inclusive package, consisting of material, machine and contract manufacturing, supported by application advice, sampling and training or you can choose the individual solutions that suit you best. We network our products and services from a single source in such a way that you receive the optimum solution for your requirements profile.

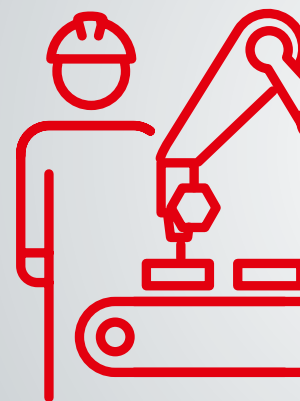

MANUFACT

Flexibility & Precision

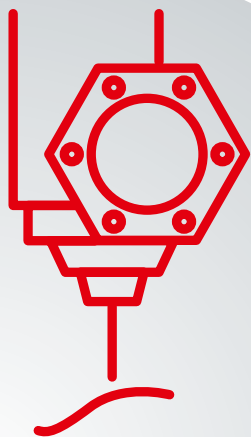

EQUIPMENT

Automation Solutions

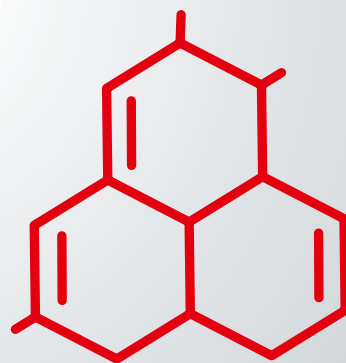

MATERIALS



URING

Customer-specific solutions – worldwide and for many industries

The Henkel specialists for the Sonderhoff portfolio
are available globally

KOLO, POLAND
External Subcontracting Location

DÜSSELDORF, GERMANY
Center of Expertise

ELGIN, ILLINOIS, USA
Regional Hub

RICHMOND (KANSAS CITY), USA
Regional Hub

DORNBIRN, AUSTRIA
Center of Expertise

BARCELONA, SPAIN
External Subcontracting Location

OGGIONO, ITALY
Regional Hub

INCHEON, KOREA
External Subcontracting Location

SHANGHAI, CHINA
Regional Hub

PUNE, INDIA
Regional Hub

PUNE, INDIA
External Subcontracting Location

SÃO PAULO, BRAZIL
External Subcontracting Location

Global presence



Every year, more than 300 million seals are manufactured in more than 50 countries using products from Henkel's Sonderhoff portfolio. At our Centers of Expertise and Regional Hubs, our specialists offer application engineering advice, e.g. selecting a suitable material system and sampling of your components, as well as project management for dosing systems and automation. You will receive training from us on how to use the FIPFG technology and we will support you with the selection of spare parts and a regular service offering. Furthermore, we will be pleased to take over parts of your production for you – from small to large series – at our subcontracting locations.

Sales staff at all other Henkel locations worldwide will also be happy to answer any questions and provide you with further information on our sealing, bonding, and potting solutions. We look forward to hearing from you.



Henkel AG & Co. KGaA

Henkelstraße 67
40589 Düsseldorf
Germany
Tel.: +49 211 797-0
Fax: +49 211 798 4008

www.henkel.com
www.sonderhoff.com

Get in contact with us



The description of the possible fields of use of our products as well as the technical data and values only have a general character and do not mean that a certain product can be used under all conditions in the respective field of use. In this respect, the stated field of use is not a binding specification or usage provision. Due to the great number of environment variables and their influences (e.g. temperature, test specimens, size, interaction with substrates, influence of machines, or the like) you as our customer must check whether the product is suitable for your specific field of use. We will be pleased to assist and advise you in this respect. Except as otherwise noted, all marks used above are trademarks and/or registered trademarks of Henkel and its affiliates in the U.S., Germany and elsewhere.

© 8.2024 Henkel AG & Co. KGaA. All rights reserved