

SEALING OF EV CHARGING STATIONS AND POTTING OF CHARGING CONNECTORS



System solutions for sealing EV charging stations and potting charging connectors

As the number of new electric vehicle sales continues to rise, the expansion of the charging infrastructure is lagging behind. The bottleneck for the rapid expansion of electromobility is the lack of public charging facilities. This means a huge increase in demand for new charging stations. The easiest way to recharge an electric car is to use your own wall charging station or wallbox in your garage at home. However, supermarkets, shopping centers, hotels, parking garages, car dealerships and public facilities are also increasingly offering parking spaces with integrated charging stations. So the goal is to have as many charging points as possible throughout the country. They should be designed to be user-friendly, but above all the charging stations must be fail-safe.

Charging stations are exposed to many unpredictable hazards and risks, especially outdoors, such as damage from vandalism, overvoltage from lightning strikes, short circuits, fire, frost, flooding, and more. In accordance with the Technical Guideline on Electromobility Charging Infrastructure (as of October 2021), charging stations must meet requirements for environmental factors depending on their location and type of use. These requirements relate, for example, to UV light resistance, mechanical resistance to vibrations and weather resistance in accordance with the appropriate IP rating, as well as corrosion and temperature resistance.

This is where Henkel's polyurethane-based 2-component foam gasket and potting systems come into play. In combination with the overall design of the charging station, the foam gasket, which is compressed when installed, reliably protects against moisture penetrating into the interior of the charging station and consequently prevents possible corrosion of the electronics and electrical connections. The cable strands in the EV charging connector housing are sealed with potting compound to make them watertight.

Are you looking for a solution consisting of a material system, dosing system, and process automation from a single source for sealing the charging stations and potting the charging connectors?

We will provide you with perfectly coordinated system solutions, consisting of a sealing foam or potting material that satisfies your requirements, and a dosing system for high-precision, fully automatic material application, controlled by contour robots.

Do you need an automation system that adapts to your production requirements?

The modular design of our mixing and dosing systems with their peripheral interfaces allows for flexible use with excellent integration into your production concepts. You will receive a very efficient system from us thanks to the high dosing and repeat accuracy of the CNC-controlled mixing head and systematic, sensor-based process monitoring.



Customized sealing solution for charging stations

We carry out developments individually for your specific requirements

The 2-component reference material FERMAPOR K31-A-6060-4-B and B-60-AD (B component) presented here in medium-high viscosity is suitable for polyurethane foam gaskets on the mostly flat or three-dimensional application surfaces of the service panel of EV charging stations and has already been tried and tested by leading manufacturers. Thanks to the mixed-cell foam structure, the closing forces when installing the polyurethane foam gasket are low. It compensates for component tolerances during sealing.

Alternatively, we offer the thixotropic 2-component silicone sealing foam FERMASIL-A-93-1-VP3-GREY and B-93-VP1 (B component) for sealing EV charging stations.

Upon request, we can also customize our material systems to meet your component requirements and specifications. Influencing factors are, for example, the pot life before foaming starts and the curing time, as well as the viscosity, hardness and adhesion properties.

Sealing the service panel with these soft-elastic foam gaskets prevents moisture, dust or other foreign bodies from penetrating into the interior of the charging station and thereby avoids, among other things, the risk of possible corrosion of the electronics and electrical connections.

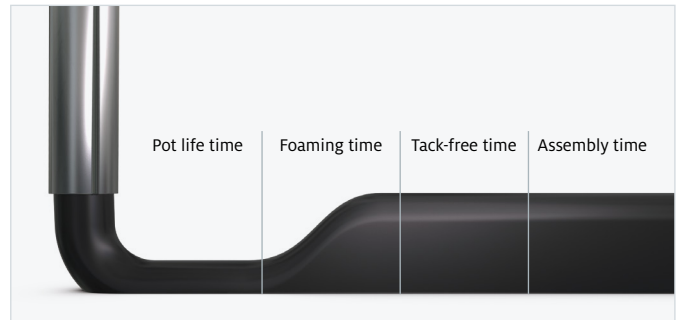

The different reaction phases of the sealing foam in the chronological sequence

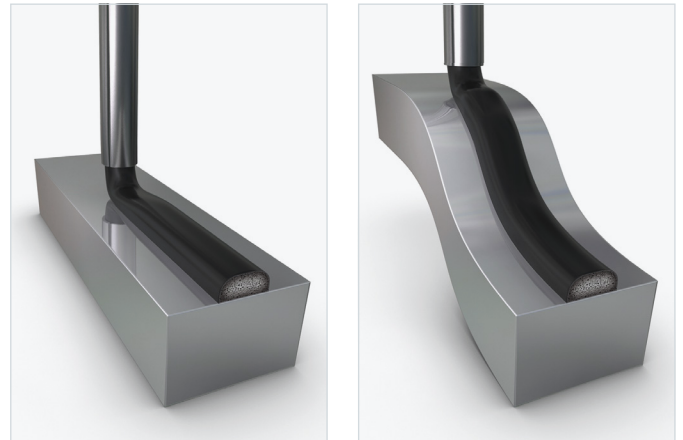

	FERMAPOR K31-A-6060-4-B FERMAPOR K31-B-60-AD	FERMASIL-A-93-1-VP3-GREY FERMASIL-B-93-VP1
Mixing ratio	4.8 : 1	1 : 1
Pot life time	26 sec.	40 sec.
Tack-free time	3.5 min.	8 min.
Viscosity of the A component	60,000 mPas	110,000 mPas
Density of the foam	0.25 g/cm ³	0.36 g/cm ³
Hardness (Shore 00)	56	62
Temperature resistance	from -40 to +80 °C	from -60 to +180 °C
Pretreatment	P23 (solvent-based) or P13 (water-based) primer	Primer P8 or TEROSON SB450



Cross-section of a polyurethane foam bead – uncompressed



Cross-section of a polyurethane foam bead, compressed to 50%



Cross-section of a silicone foam bead in the groove without compression



Cross-section of a silicone foam bead in the groove and compressed to approx. 30%

The contour-accurate, robot-controlled Formed-In-Place-Foam-Gasket (FIPFG) application process is crucial for the precise application of sealing foams to the usually flat or three-dimensional application surfaces of the EV charging station service panel. This is done very precisely, safely and efficiently with our fully automatic DM 502 mixing and dosing machine.

When the service panel is closed, the foam gasket is compressed evenly over the entire length of the component contour and, when built into the overall structure of the charging station, produces a high level of impermeability in accordance with IP ratings. Due to its excellent shape recovery characteristics, the mixed-cell foam structure of the polyurethane seal can still be compressed well even after years (tested according to DIN EN ISO 1856). It is therefore possible to repeatedly open and close the service panel of EV charging stations for maintenance purposes while maintaining the sealing effect of the foam gasket.

The reference material FERMAPOR K31-A-6060-4-B generally achieves excellent adhesion to powder coatings and plastic surfaces. In special cases, adhesion can be improved by flame or corona pretreatment and by primer or plasma application.

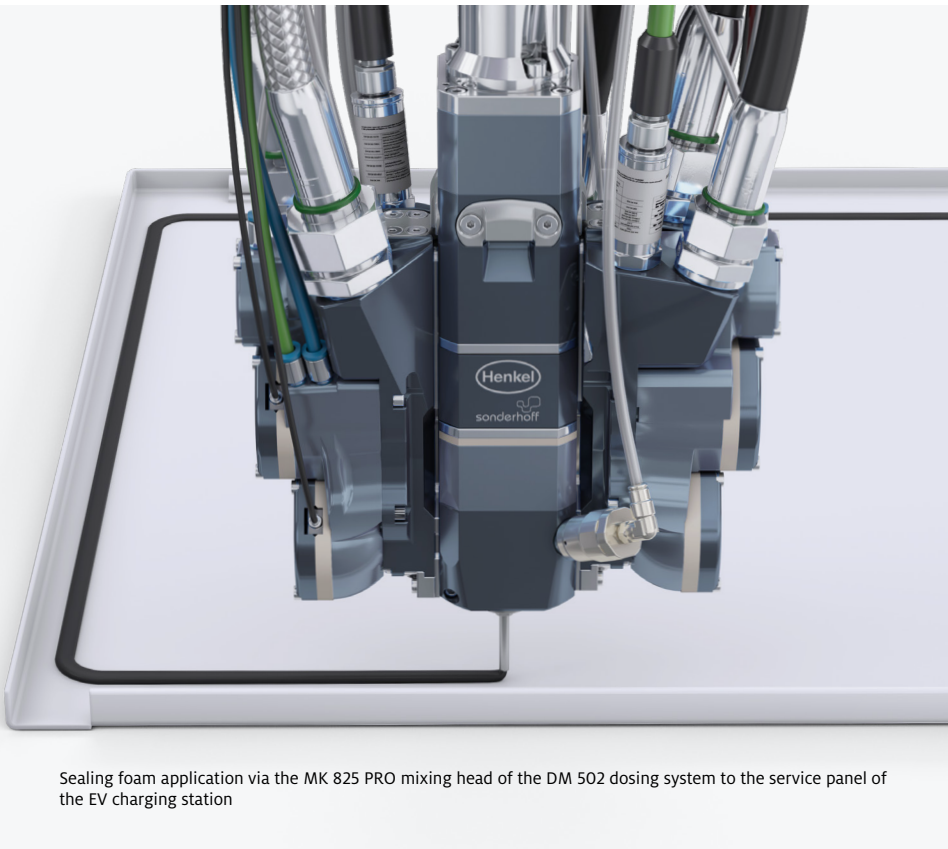

Sealing foam application via the MK 825 PRO mixing head of the DM 502 dosing system to the service panel of the EV charging station



EV charging station service panel with foam sealing

Flexible and fully automatic – fully in line with your requirements

Mixing and dosing system with 3-axis linear robot and shuttle table for sealing service panels of EV charging stations

With the reference configuration shown here for sealing service panels of EV charging stations, we offer a perfectly coordinated system solution: a sealing foam that meets your requirements and a dosing system for high-precision and fully automatic material application controlled by contour robots. The configuration consists of the DM 502 mixing and dosing system with the MK 825 PRO precision mixing head and a 3-axis linear robot and shuttle table. The two WT 1-LEVEL shuttle table plates allow parts to be picked up and machined in continuous shuttle mode, operating in a single plane. Alternatively, we can offer the WT 2-LEVEL shuttle table with pick-up plates operating in shuttle mode, one above the other in two planes.

The highly efficient LR-HE plus 3-axis linear robot or alternatively the highly dynamic LR-HD ensures contour-precise guidance of the mixing head above the service panel. The sealing foam is fully automatically applied to the pre-programmed contour of the service panel with high dosing accuracy. After the dosing cycle, the coupling point of the foam gasket closes seamlessly and is therefore almost invisible. The applied material foams, expanding to several times its original volume, and forms an elastic soft foam gasket with the desired foam hardness at room temperature.

Our mixing and dosing machines can be operated easily and intuitively without requiring much training. Thanks to the automatic logging of dosing program data, all process data can be traced and evaluated by the machine operator via the CONTROL 2 operating panel while production is running.

In all solutions, our main focus is on extremely reliable plant engineering, minimized maintenance times and consistent dosing quality. As process experts, we support you with tailored advice for the automation of your manufacturing processes.

Even with short cycle times and large unit numbers, the material application process is carried out in the FIPFG (Formed-In-Place-Foam-Gasket) process with high dosing and repeat accuracy. As a result, when you install the service panel in the overall structure of your EV charging station, you get a foam gasket with consistently high quality and impermeability.



Optionally available: **CONTROL 2 touchscreen operating panel (21.5")** for operating the dosing system



Optional: **WT 2-LEVEL shuttle / sliding table** Two pick-up plates operating in shuttle mode in two planes



WT 1-LEVEL shuttle / sliding table Two pick-up plates operating in shuttle mode in one plane



The multifunctional **MP 2 mobile panel (10.1" WXGA TFT)** enables convenient operation of the dosing system.

Highly efficient **LR-HE plus 3-axis linear robot** for precise guidance of mixing heads for the application of polymer reaction materials. The Omega toothed belt drive enables high application speeds for components with medium and large radii.

Optional: Highly dynamic **LR-HD 3-axis linear robot** for precise guidance of mixing heads for the application of polymer reaction materials. The rack-and-pinion drive with high stiffness and acceleration enables dynamic application speeds.

Optional: Automatic **SUPPLY TAB drum refilling station** for low-viscosity products, e.g. isocyanate (**B component**)

Optional: Automatic **ELEVATOR drum refilling station** for the **A component** with pneumatic lift and agitator

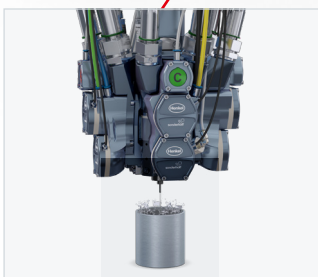
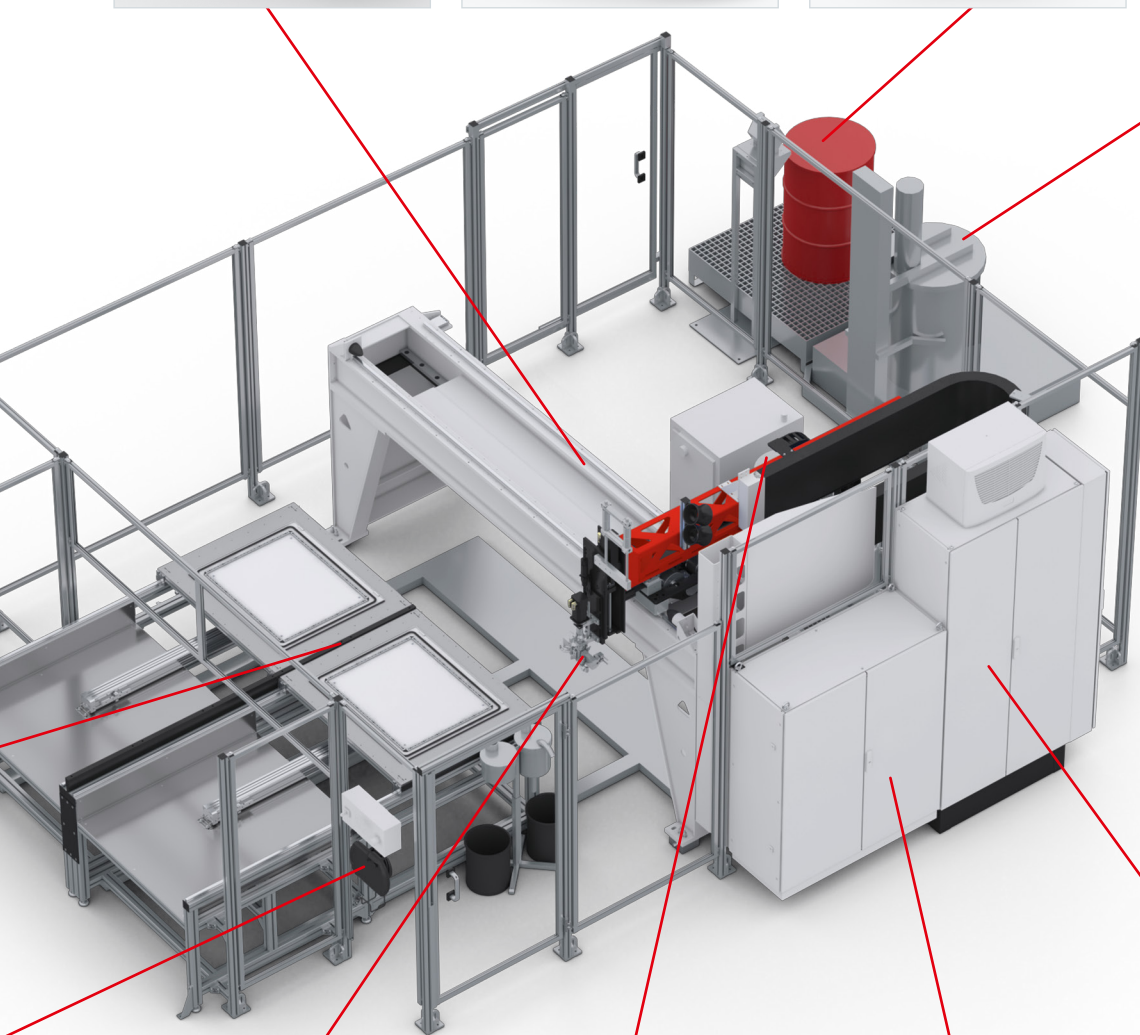
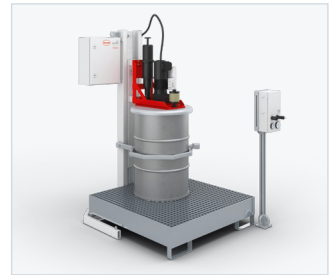

MK 825 PRO precision mixing head with high-pressure water rinsing



Separately installed **material pressure tanks** (24 l or 44 l, single-walled or double-walled) with minimum level sensors, on a grating platform with adjustable leveling feet and drip tray

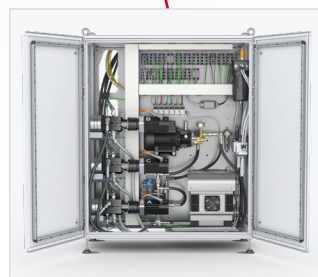

The **dosing machine cabinet** contains the components of the dosing periphery, e.g. the dosing pumps.



The control electronics, safety engineering and industrial PC are installed in the **control cabinet**.

Customized sealing solution for the EV wallbox

We carry out developments individually for your specific requirements

For charging the private electric vehicle in carports or garages, a permanently installed wall charging station or a wallbox attached to the wall is used. They are usually already equipped with a ground fault circuit interrupter (class B) specially developed for the requirements of electromobility to detect all types of AC and DC fault currents. This protects against unforeseeable risks that would be caused by improper use of extension cords, multiple outlets or via existing outlets in living areas or basements.

However, protection against the ingress of dust or other foreign bodies as well as moisture into the interior of the two-part wallbox housing must also be ensured to prevent potential corrosion of the electronics and electrical connections.

The reference material FERMAPOR K31-A-9675-2-VP and B-4 (B component) is used for this purpose by leading manufacturers. It is a 2-component polyurethane sealing foam that cures at room temperature and compensates for component tolerances during sealing. If necessary, curing can be accelerated by using an annealing oven. For outdoor use of the wallbox, the two-component silicone sealing foam FERMASIL-A-91-VP2 and B-91 (B component) can be used as an alternative.

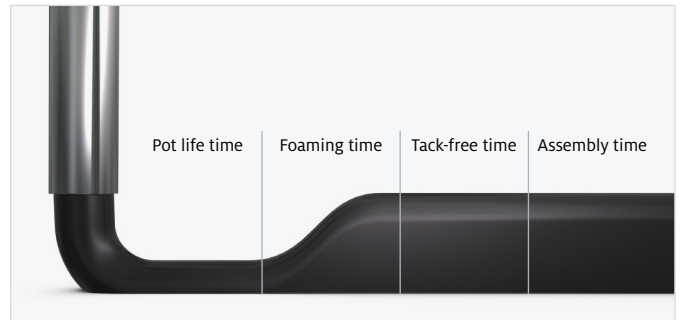

The different reaction phases of the sealing foam in the chronological sequence



	FERMAPOR K31-A-9675-2-VP FERMAPOR K31-B-4 (UL 50e)	FERMASIL A-91-VP2 FERMASIL B-91
Mixing ratio	4 : 1	1 : 1
Pot life time	38 sec.	56 sec.
Tack-free time	3.5 min.	5 min.
Viscosity of the A component	1,800 mPas	15,000 mPas
Density	0.34 g/cm ³	0.30 g/cm ³
Hardness (Shore 00)	64	52
Temperature resistance	from -40 to +80 °C	from -60 to +180 °C
Pretreatment	Plasma, Corona or Primer	Primer P8 or TEROSON SB450



Cross-section of a polyurethane foam bead in the groove without pressing



Cross-section of a polyurethane foam bead in the groove and compressed to approx. 50 %



Cross-section of a silicone foam bead in the groove without compression



Cross-section of a silicone foam bead in the groove and compressed to approx. 30%

Alternatively, we can also customize our material systems to meet your component requirements and specifications. Influencing factors are, for example, the pot life before foaming starts and the curing time, as well as the viscosity, hardness and adhesion properties. Thanks to the mixed-cell foam structure, the closing forces when installing the polyurethane foam gasket are low.

The contour-accurate foam application into the groove of the two- or three-dimensional wallbox housings is carried out with the robot-controlled Formed-In-Place-Foam-Gasket (FIPFG) technology of our DM 502 mixing and dosing machine – in a fully automatic, precise, safe and efficient way.

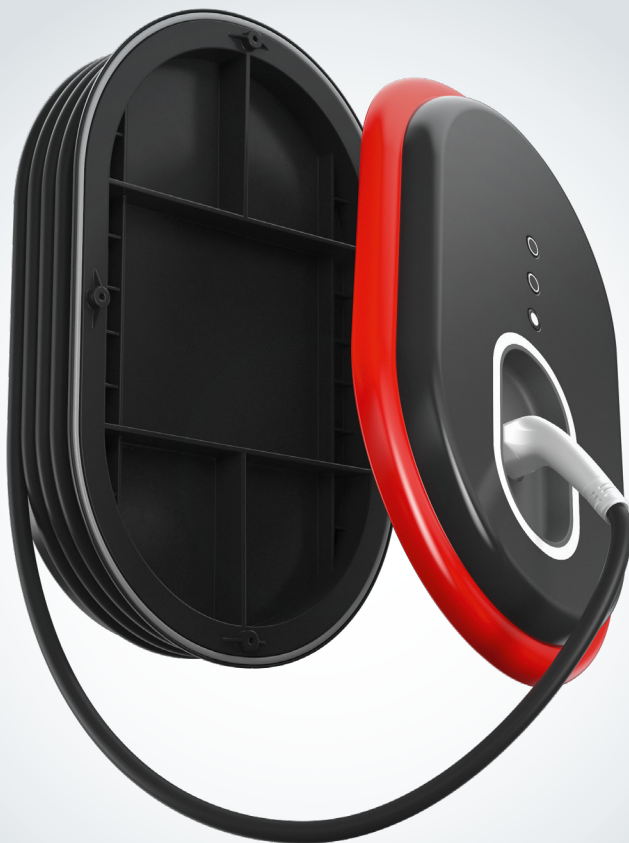

Wallbox housing sealed with sealing foam

When the wallbox housing, which consists of two parts, is assembled, the foam gasket is compressed evenly over the entire length of the component contour, resulting in a high level of tightness with excellent long-term behavior. Due to its excellent shape recovery characteristics, the mixed-cell foam structure of the polyurethane seal can still be compressed well even after years (tested according to DIN EN ISO 1856). It is therefore possible to repeatedly open and close the wallbox for maintenance purposes while maintaining the sealing effect of the foam gasket.

Flexible and fully automatic – fully in line with your requirements

Mixing and dosing system with 3-axis linear robot and shuttle table for sealing EV wallbox housings with sealing foam

The reference configuration for sealing the wallbox housings shown here consists of the DM 502 mixing and dosing system and the MK 825 PRO precision mixing head, as well as a 3-axis linear robot and the WT 1-LEVEL shuttle table for picking up parts.

The placement of the wallbox housings on the shuttle table plate is carried out by a machine operator, who can also check the parts for quality, or alternatively by a Pick & Place robot. In the latter case, an optionally installed camera or sensor system could carry out the quality control of the parts. Parts are then machined in continuous shuttle mode of the two shuttle table plates in one plane.

The highly dynamic LR-HD 3-axis linear robot or alternatively the highly efficient LR-HE plus ensures contour-precise guidance of the mixing head above the EV wallbox housing. During this process, the sealing foam is inserted very precisely into the groove of the two- or three-dimensional wallbox housing. Immediately after the dosing cycle, the applied material expands by several times its volume and the room-temperature curing of the material begins. This results in a seamless, soft-elastic foam gasket of the desired foam hardness with an almost invisible coupling point.

Even with short cycle times and high unit numbers, the material application process using the FIPFG method is carried out with high dosing precision and repeat accuracy. As a result, you get foam gaskets of consistently high quality.

Thanks to the automatic logging of dosing program data, all process data can be traced and evaluated by the machine operator via the CONTROL 2 operating panel while production is running.



Optionally available: **CONTROL 2** touchscreen operating panel (21.5") for operating the dosing system



WT 1-LEVEL shuttle / sliding table
Two pick-up plates operating in shuttle mode in one plane



The multifunctional **MP 2 mobile panel** (10.1" WXGA TFT) enables convenient operation of the dosing system.

Highly dynamic **LR-HD 3-axis linear robot** for precise guidance of mixing heads for the application of polymer reaction materials. The rack-and-pinion drive with high stiffness and acceleration enables dynamic application speeds.

Optional: Highly efficient **LR-HE plus 3-axis linear robot** for precise guidance of mixing heads for the application of polymer reaction materials. The Omega toothed belt drive enables high application speeds for components with medium and large radii.

Optional: Automatic **SUPPLY TAB drum refilling station** for low-viscosity products, e.g. isocyanate (**B component**)

Optional: Automatic **ELEVATOR drum refilling station** for the **A component** with pneumatic lift and agitator

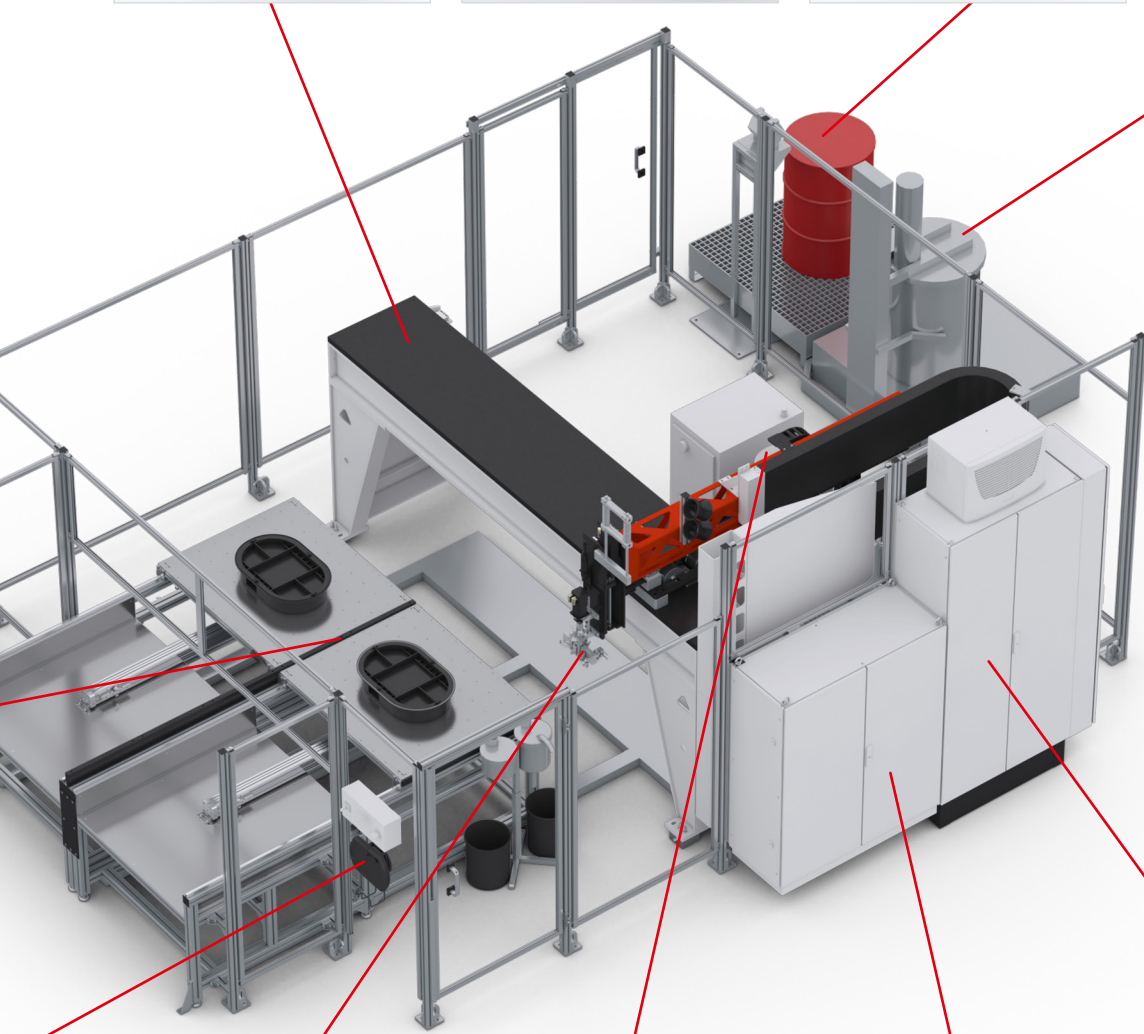

MK 825 PRO precision mixing head with high-pressure water rinsing



Separately installed **material pressure tanks** (24 l or 44 l, single-walled or double-walled) with minimum level sensors, on a grating platform with adjustable leveling feet and drip tray

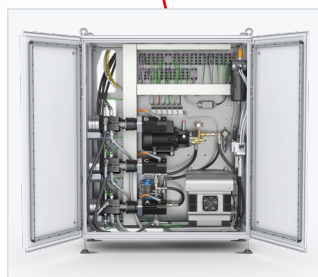

The **dosing machine cabinet** contains the components of the dosing periphery, e.g. the dosing pumps.



The control electronics, safety engineering and industrial PC are installed in the **control cabinet**.

Customized potting systems for maximum product safety

Potting of cable strands in the EV charging connector housing with polyurethane potting compound

The reference material FERMADUR-A-690-UL1 and B-N (B component) is used to seal the cable strands in the EV charging connector housing to make them watertight. This 2-component polyurethane compound cures at room temperature and is temperature resistant from -40 to +80 °C. It is mechanically particularly stable and tear-resistant as well as low-shrinkage and low-stress. This increases dielectric strength and protection against moisture and corrosion. As a rule, polyurethane potting compounds have good adhesion to plastic surfaces. As an alternative to the reference material presented, we can also adapt our potting systems to your component requirement and specification.

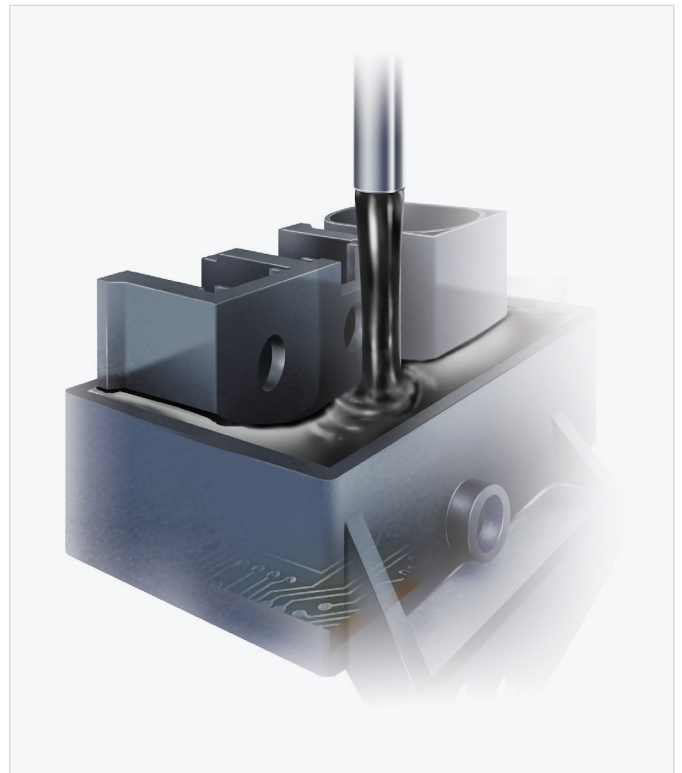

Dosing of polyurethane potting compound into the component via the CNC-controlled mixing head of the DM 502 dosing system

FERMADUR	A-690-UL1
	B-N
Mixing ratio	3 : 1
Pot life time	130 sec.
Tack-free time	4 min.
Viscosity of the A component	5,000 mPas
Density of the foam	1.55 g/cm ³
Hardness (Shore D)	84
Temperature resistance	from -40 to +80 °C
Pretreatment	Plasma / Corona / Primer



EV charging connector



Cross-section of EV charger connector with waterproof potted cable strands

The FERMADUR polyurethane compound is applied bubble-free into the receptacles of the cable strands in the charging connector housing using the FIP (Formed-In-Place) technology of our DM 502 mixing and dosing machine via the CNC-controlled MK 825 PRO precision mixing head with high dosing and repetition accuracy.

After dosing, a smooth, even finish is formed which does not show any shrinkage. After curing at room temperature, which can be optionally accelerated by an annealing oven, a compact seal of the desired hardness is produced.

Our potting systems and the fully automated application process for potting the cable strands in the EV charging connector housing are optimally matched to each other and adapted to your specific component requirements.

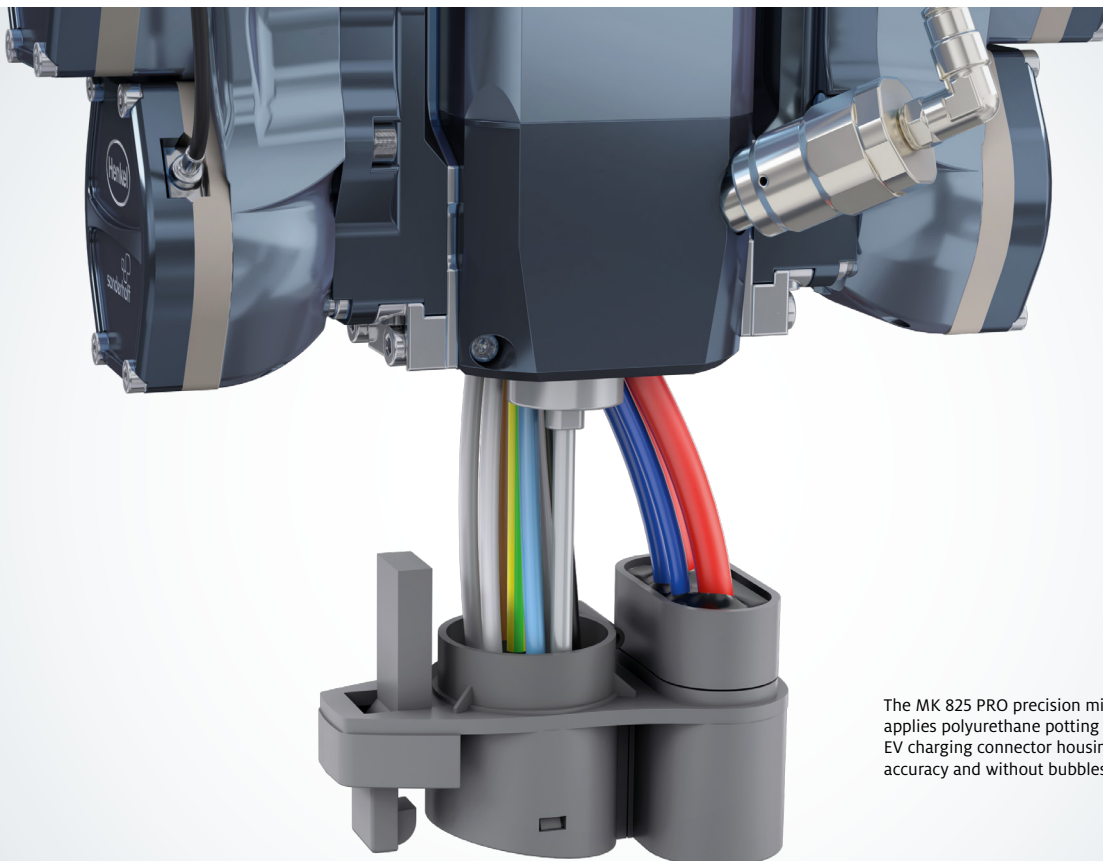

The MK 825 PRO precision mixing head applies polyurethane potting compound to the EV charging connector housings with dimensional accuracy and without bubbles.

Flexible and fully automatic – fully in line with your requirements

DM 502 mixing and dosing system with 6-axis robot and shuttle table for potting EV charging connector housings with polyurethane potting compound

The reference configuration shown here for potting the cable strands in the EV charging plug housing consists of the DM 502 mixing and dosing system for two material components using a 6-axis robot and the WT 1-LEVEL shuttle table. A machine operator or, optionally, a Pick & Place robot places the EV charging connector housings and the coiled charging cable on the part holders of the shuttle table plate and inserts the cable strands into the charging plug sockets in preparation for the potting process. Potting of the cable strands in the receptacles of the housing is performed by the mixing head of the DM 502 in continuous shuttle mode of the two pick-up plates in one plane.

The 6-axis robot ensures repeatable accuracy in guiding the robot arm's MK 825 PRO precision mixing head over the component. During this process, FERMADUR polyurethane material is fed into the receptacles of the charging plug housing for potting the cable strands in a fully automatic process with high dosing accuracy and dimensional precision. The dosing nozzle reaches as deep as possible into the component so that it is filled from the bottom to the top without bubbles or air pockets being formed. After curing, a compact seal of the desired hardness is formed and the cable strands are therefore firmly connected to the connector and protected.

Where components are to be applied with a combination of both potting and sealing foam in a single production step, the dosing application can be carried out with the DM 503 mixing and dosing system for 3 material components which is equipped with three pressure vessels to supply the material.

Our fail-safe mixing and dosing systems can be operated easily and intuitively without the need for extensive training. Thanks to the automatic logging of dosing program data, all process data can be traced and evaluated by the machine operator via the CONTROL 2 operating panel while production is running.

As process experts, we support you with tailored advice for the automation of your manufacturing processes.



Optionally available: **CONTROL 2 touchscreen operating panel (21.5")** for operating the dosing system



WT 1-LEVEL shuttle/sliding table
Two pick-up plates operating in shuttle mode in one plane



The multifunctional **MP 2 mobile panel (10.1" WXGA TFT)** enables convenient operation of the dosing system.

MK 825 PRO precision mixing head with high-pressure water rinsing

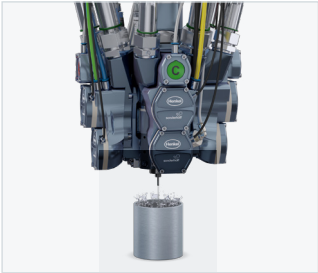

The control electronics, safety engineering and industrial PC are installed in the **control cabinet**.



Optional: Automatic **ELEVATOR drum refilling station** for the **A component** with pneumatic lift and agitator

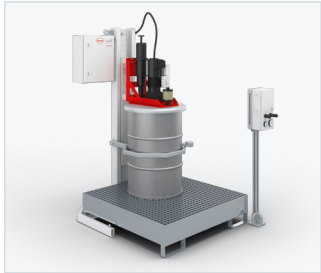

Optional: Automatic **SUPPLY TAB drum refilling station** for low-viscosity products, e.g. isocyanate (**B component**)

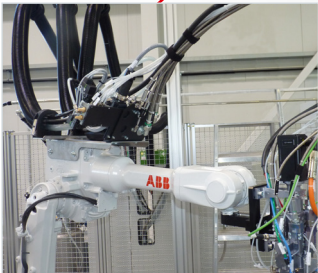
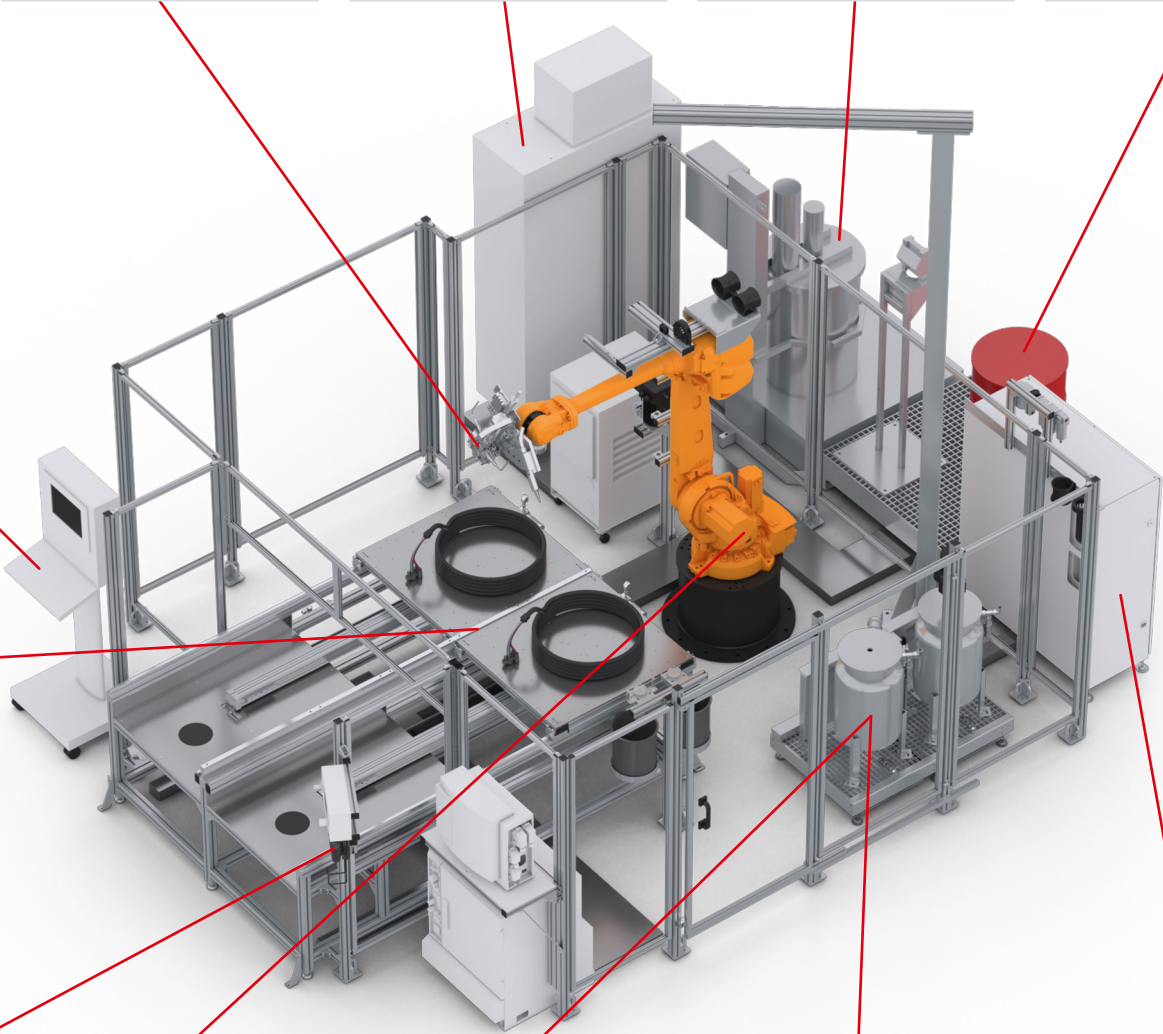

The **6-axis robot** guides the mixing head with repeated accuracy over the charging plug housing for precise potting of the cable strands with the connector.



Separately installed **material pressure tanks** (24 l or 44 l, single-walled or double-walled) with minimum level sensors, on a grating platform with adjustable leveling feet and drip tray



Separately installed **material pressure tanks** (24 l or 44 l, single-walled or double-walled) for the DM 503 mixing and dosing system for three material components



The **dosing machine cabinet** contains the components of the dosing periphery, e.g. the dosing pumps.



sonderhoff

This is why you should use the FIPFG technology in your production process

- +** **Advantages of the Formed-In-Place Foam Gasket Technology**
- › Sealing standard in many industrial sectors
 - › Highly accurate material application controlled by contour robots
 - › Processing and full curing at room temperature
 - › Perfect coordination of the material system and dosing system
 - › Suitable for 2D and complex 3D part geometries
 - › More efficient use of materials compared to punched seals
 - › Cheaper compared to 2-C injection molding, as there are no tooling costs
 - › High degree of future viability, due to suitability for use in a wide variety of industries & applications



Advantages of our mixing and dosing machines

- › Combination of processes (bonding, foaming, caulking, potting)
- › High flexibility of the dosing system
- › Simple, intuitive operation
- › Automatic material preparation incl. handling
- › High dosing and repeat accuracy
- › Short machine downtimes and cycle times
- › Fine-cell foam structure due to dynamic mixing
- › Reproducible foam quality
- › Ecological high-pressure water rinsing
- › Easy maintenance



Advantages of our FIPFG foam gaskets

- › More cost-effective than compact systems due to lower foam density
- › Seamless seal / hardly visible coupling point
- › Compensation of component tolerances
- › Good resilience
- › Multiple compression and release processes possible
- › Broad range of properties / wide variety of recipes
- › Individually adaptable recipes
- › Good form fit to the component contour
- › Resistant to moisture, dust, temperature & media
- › Flame-retardant according to UL 94
- › IP classes up to IP 68 or NEMA 4 to 6 and NEMA 12
- › Special PU foam with low VOC emissions
- › Very fast reacting PU foam (Fast-Cure)

Perfectly coordinated solutions of material, machine and contract manufacturing

With its Sonderhoff brand, Henkel has not only acquired many years of experience in the manufacture of tailor-made two-component sealing systems and mixing and dosing machines, but also as a process expert for application-specific material application using the FIPFG (Formed-In-Place-Foam-Gasket) technology.

With the Sonderhoff portfolio, we offer you the advantages of a system provider from a single source and the solutions to meet your technical and commercial challenges.

With the dosing technology that is tailored to our sealing foams, we ensure efficient production processes in accordance with the requirements of fully automated series production.

If you would like to take advantage of all the benefits of the FIPFG technology for your production in a flexible, fast, uncomplicated manner and without having to make your own acquisition investments, we can provide expert sealing for your components at one of our contract manufacturing sites worldwide. There, the spectrum ranges from the sampling of prototypes and small batch series to production scale manufacturing.

The choice is yours! You can either decide in favor of our all-inclusive package, consisting of material, machine and contract manufacturing, supported by application advice, sampling and training or you can choose the individual solutions that suit you best. We combine our products and services from a single source in such a way that you receive the optimum solution for your requirements profile.

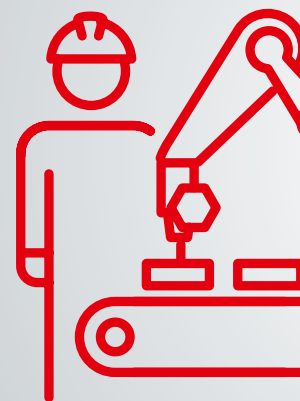

MANUFACT

Flexibility & Precision

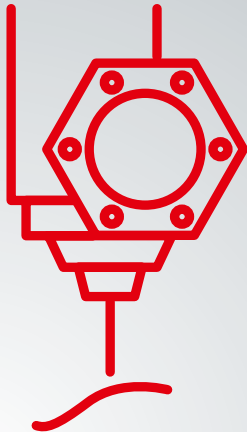

EQUIPMENT

Automation Solutions

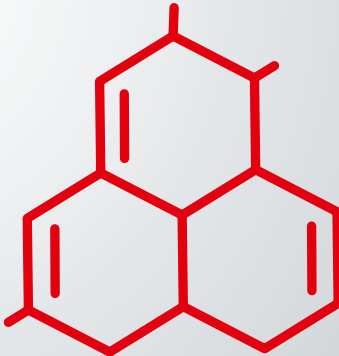

MATERIALS

MANUFACTURING

Customer-specific solutions – worldwide and for many industries

The Henkel specialists for the Sonderhoff portfolio
are available globally

KOLO, POLAND
External Subcontracting Location

DÜSSELDORF, GERMANY
Center of Expertise

ELGIN, ILLINOIS, USA
Regional Hub

RICHMOND (KANSAS CITY), USA
Regional Hub

DORNBIRN, AUSTRIA
Center of Expertise

BARCELONA, SPAIN
External Subcontracting Location

OGGIONO, ITALY
Regional Hub

INCHEON, KOREA
External Subcontracting Location

SHANGHAI, CHINA
Regional Hub

PUNE, INDIA
Regional Hub

PUNE, INDIA
External Subcontracting Location

SÃO PAULO, BRAZIL
External Subcontracting Location

Global presence



Every year, more than 300 million seals are manufactured in more than 50 countries using products from Henkel's Sonderhoff portfolio. At our Centers of Expertise and Regional Hubs, our specialists offer application engineering advice, e.g. selecting a suitable material system and sampling of your components, as well as project management for dosing systems and automation. You will receive training from us on how to use the FIPFG technology and we will support you with the selection of spare parts and a regular service offering. Furthermore, we will be pleased to take over parts of your production for you – from small to large series – at our subcontracting locations.

Sales staff at all other Henkel locations worldwide will also be happy to answer any questions and provide you with further information on our sealing, bonding, and potting solutions. We look forward to hearing from you.



Henkel AG & Co. KGaA

Henkelstraße 67
40589 Düsseldorf
Germany
Tel.: +49 211 797-0
Fax: +49 211 798 4008

www.henkel.com
www.sonderhoff.com

Get in contact with us



The description of the possible fields of use of our products as well as the technical data and values only have a general character and do not mean that a certain product can be used under all conditions in the respective field of use. In this respect, the stated field of use is not a binding specification or usage provision. Due to the great number of environment variables and their influences (e.g. temperature, test specimens, size, interaction with substrates, influence of machines, or the like) you as our customer must check whether the product is suitable for your specific field of use. We will be pleased to assist and advise you in this respect. Except as otherwise noted, all marks used above are trademarks and/or registered trademarks of Henkel and its affiliates in the U.S., Germany and elsewhere.

© 8.2024 Henkel AG & Co. KGaA. All rights reserved