

# SEALING OF CONTROL CABINETS & ELECTRICAL DISTRIBUTION BOXES

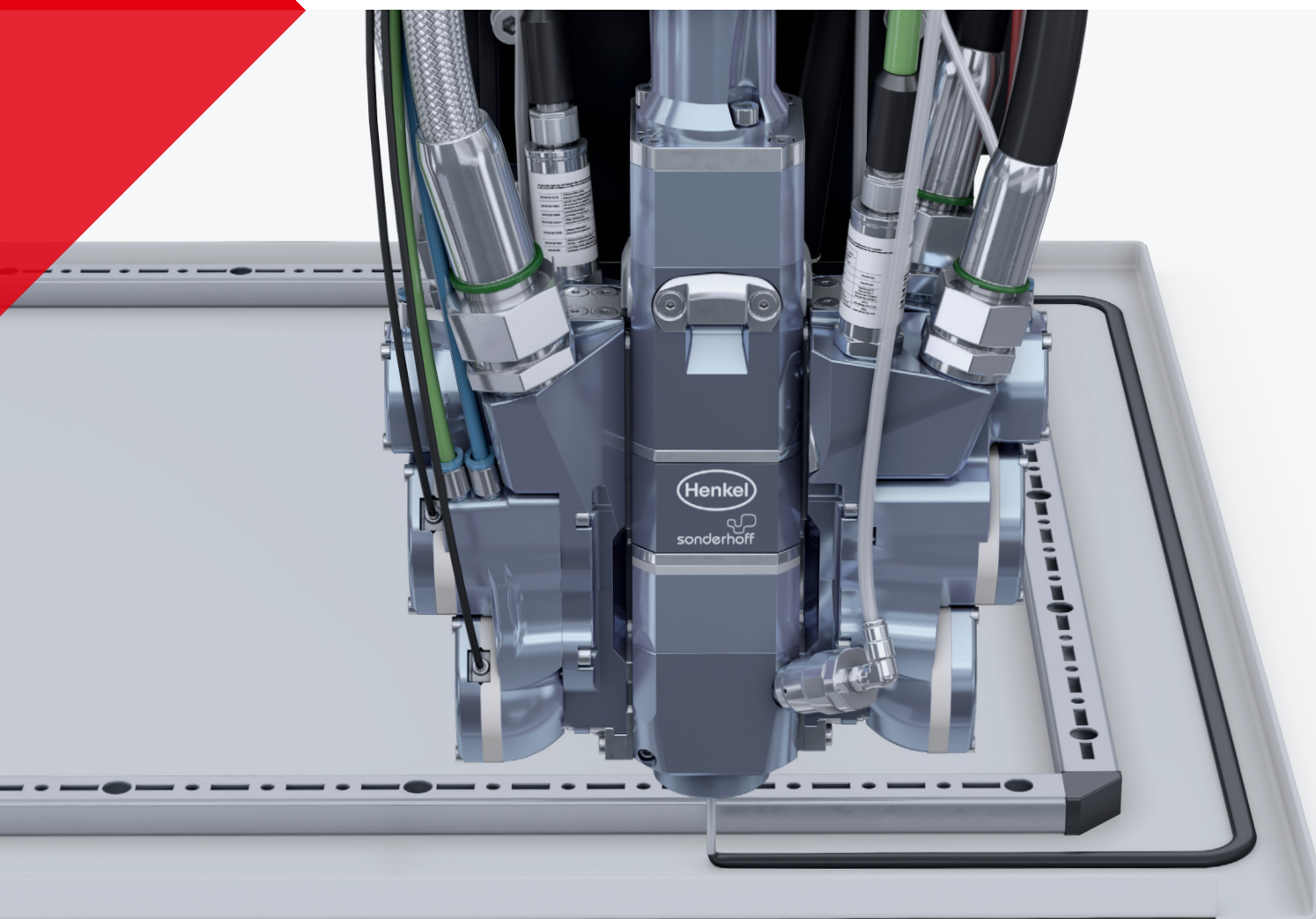

# Automated sealing solution for control cabinet construction

The lifelines of highly automated industrial production for electrical distribution and for the control and safety technology of manufacturing plants come together in control cabinets and electrical distribution boxes right down to the micro distribution boards.

Control cabinets protect and maintain the function of the “brain” (the control system) of a machine or plant in the best possible way against malfunctions and mechanical damage. As the digitalization and automation of the production facilities progresses towards Industry 4.0, control cabinets also include the manufacturing execution systems for the process automation, control and monitoring of production in real time.

For trouble-free production and protection of the installed electronic devices, the modular control cabinet must be optimally sealed in its overall construction. This includes the rear wall, side panels, doors, door handle and ventilation grille with climate filter for the air intake. And the control cabinet standard DIN EN 61439 (IEC 61439) stipulates that control cabinets must be equipped with a seamless gasket. It is achieved through the automated, contour-accurate application of a liquid seal consisting of two components that flow seamlessly into one another at its coupling point. As a result, it is almost invisible. The cut edges of glued-in seals are therefore avoided. After foaming and curing at room temperature, a seamless soft foam gasket is created over the entire contour of the parts.

Are you looking for a flexible automation system for the sealing of your control cabinet construction that fits to your production conditions?

Through our combination of individual material systems, customer-specific mixing and dosing machines and skilled process expertise, we offer system solutions to meet your technical and commercial requirements.

Do you ask yourself how you can make your production processes more efficient with a high volume of parts and short cycle times?

You can create cost-efficient manufacturing processes through the use of our fast-reacting 2-component FERMAPOR K31 FAST-CURE polyurethane foams. Longer curing lines or intermediate storage for the just sealed parts are no longer necessary. Thanks to the short tack-free time of the sealing foams, the control cabinet parts can be further processed very fast until final assembly.

Henkel’s polyurethane or silicone sealing foams protect the electronics in control cabinets and electrical distribution boxes against external influences, such as moisture and dust, which can cause against corrosion and contamination. Malfunctions or even the failure of the control electronics in the control cabinet, which would otherwise lead to major damage and production downtimes with high costs for your customers, are therefore avoided.



# Tailor-made material systems for powder-coated control cabinets

We develop customized solutions for your specific requirements

Often, a control cabinet is a powder-coated metal housing. These offer great advantages in terms of stability, flexibility in use, impact resistance, electromagnetic compatibility (EMC) and resistance to UV radiation. The powder coating gives the control cabinet a permanent corrosion protection for outdoor installation. However, control cabinets can also be made of plastic or sheet molding compound (SMC). Our polyurethane foams generally offer good adhesion to powder-coated surfaces. This can be further improved by pretreatment with primers.

Paste-like (thixotropic) polyurethane sealing foam of the FERMAPOR K31 product family is applied to the control cabinet parts with contour accuracy using our fully automatic DM 502 mixing and dosing machine or, alternatively, the 3E dosing cell. Due to its high viscosity, the applied foam remains stable on the flat surface of the control cabinet panels and doors. After final assembly, the control cabinet is seamlessly sealed in accordance with DIN EN 61439 (IEC 61439) and its overall construction is impervious.

With more than 30 years of practical experience of control cabinet construction, the foam gasket (tested according to DIN EN ISO 1856) shows very good recovery behavior (DVR) even after years of use. It allows frequent opening and re-closing of the control cabinet door while maintaining a consistently high level of impermeability.

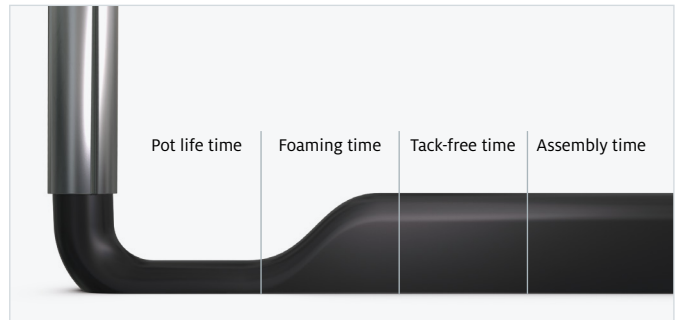

The different reaction phases of the sealing foam in the chronological sequence

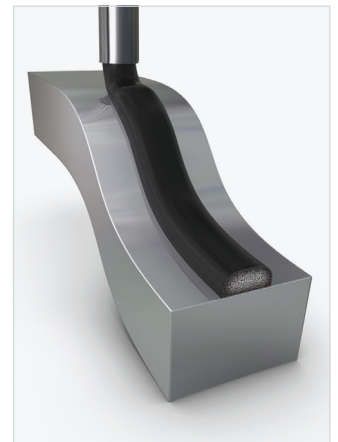

	Powder coating Indoor	Powder coating Outdoor	Powder coating UL 94 V-2
<b>FERMAPOR K31-</b>	A-4525-1-B-UL B-4	A-6060-4-B B-60-AD	A-45C2-1-UL-FR B-16-FR
<b>Mixing ratio</b>	4.3 : 1	4.8 : 1	5.7 : 1
<b>Pot life time</b>	30 sec.	26 sec.	27 sec.
<b>Tack-free time</b>	4 min.	3.5 min.	4 min.
<b>Viscosity of the A component</b>	30,000 mPas	60,000 mPas	135,000 mPas
<b>Density</b>	0.24 g/cm <sup>3</sup>	0.25 g/cm <sup>3</sup>	0.24 g/cm <sup>3</sup>
<b>Hardness (Shore 00)</b>	45	56	47
<b>Temperature resistance</b>	from -40 to +80 °C	from -40 to +80 °C	from -40 to +80 °C



Cross-section of a polyurethane foam bead – unpressed



Cross-section of a polyurethane foam bead with 50% compression

Our polyurethane sealing foams for control cabinet construction are characterized by a large number of specific properties:

- Short installation and tack-free times thanks to very fast-reacting Fast-Cure foam gaskets for indoor and outdoor use
- High flame retardancy according to UL 94 V-2
- Resiliency of > 95% (DVR < 5%), tested according to DIN EN ISO 1856:2020
- Very good adhesion to most powder coatings
- Type of protection up to IP 68 or NEMA 4 and 12 (depending on the component design and foam system)
- US test standards UL 50E in non-explosion-proof areas
- Optional adjustability of a microbially inert protection function against mold and fungal infestation

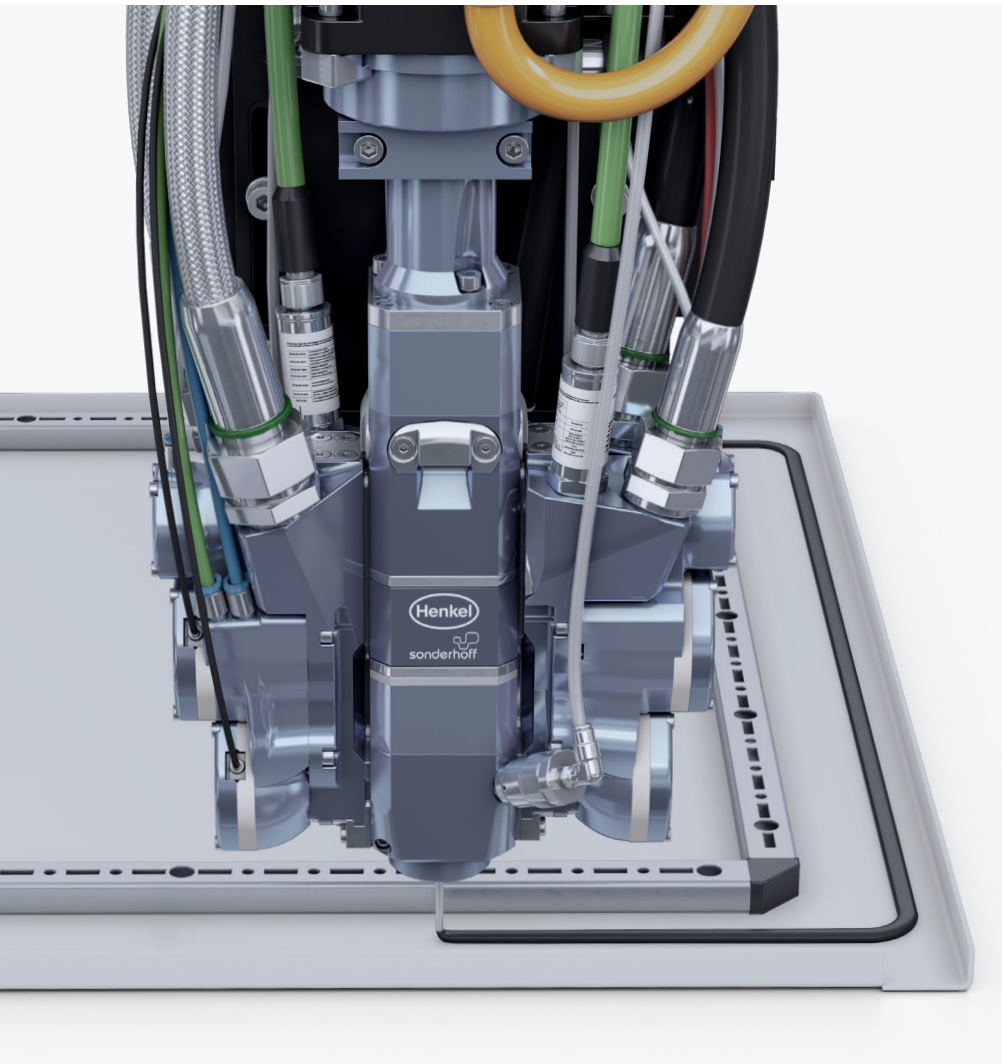

Polyurethane foam with flame retardancy according to UL 94 V-2



Water resistance up to IP 68 or NEMA 4 and 12 in the overall construction

# Material systems for stainless steel control cabinets – also with ATEX suitability

We develop customized solutions for your specific requirements

Stainless steel control cabinets are sealed for indoor and outdoor use with suitable polyurethane sealing foams from the FERMAPOR K31 product family.

In accordance with the European Union’s ATEX directives, explosion-proof control cabinets used in mining, chemical or oil industries are sealed with are sealed with FERMASIL temperature-resistant silicone foams. We fulfill the IEC 60079 standard for electrotechnical equipment with explosion protection and your requirements for the ATEX approval of explosion-proof control cabinets. Good adhesion to stainless steel surfaces is achieved by pretreatment with primer.

Paste-like (thixotropic) sealing foam consisting of polyurethane or silicone is applied to the control cabinet parts with contour accuracy using our fully automatic DM 502 mixing and dosing machine. Due to its high viscosity, the applied foam remains stable on the flat surface of the control cabinet panels and doors. After final assembly, the control cabinet is seamlessly sealed in accordance with DIN EN 61439 (IEC 61439) and its overall construction is impervious.

If you are interested in a 3E dosing cell for the application of silicone foam gaskets, we will be pleased to offer this to you as well.

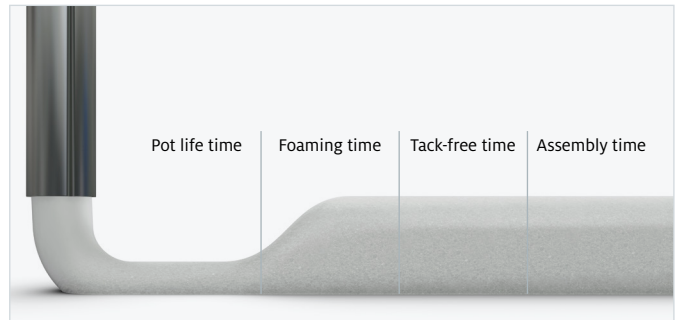

The different reaction phases of the sealing foam in the chronological sequence

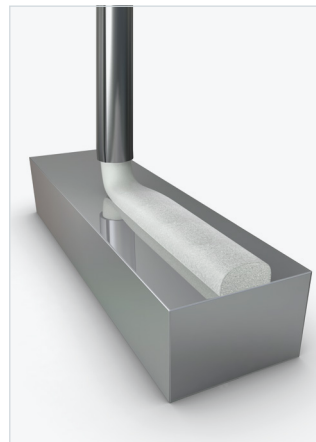

	Stainless steel Indoor / Outdoor	Stainless steel Special Requirement (ATEX Cleanroom)
	FERMAPOR K31-A-6060-4-B	FERMASIL-A-93-1-VP3-GREY
	FERMAPOR K31-B-60-AD	FERMASIL-B-93-VP1
<b>Mixing ratio</b>	4.8 : 1	1 : 1
<b>Pot life time</b>	26 sec.	40 sec.
<b>Tack-free time</b>	3.5 min.	8 min.
<b>Viscosity of the A component</b>	60,000 mPas	110,000 mPas
<b>Density</b>	0.25 g/cm <sup>3</sup>	0.36 g/cm <sup>3</sup>
<b>Hardness (Shore 00)</b>	56	62
<b>Temperature resistance</b>	from -40 to +80 °C	from -60 to +180 °C
<b>Pretreatment</b>	P23 (solvent-based) or P13 (water-based) primer	Primer P8 or TEROSON SB450



Cross-section of a silicone foam bead – unpressed

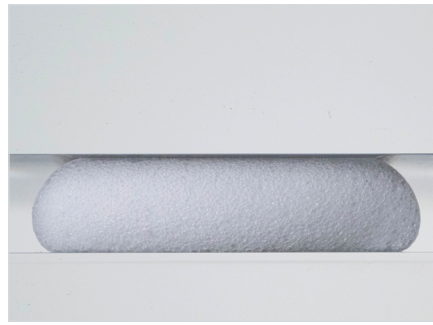

Cross-section of a silicone foam bead with 30% compression

Our polyurethane and silicone foam gaskets fulfill the types of protection up to IP 68 or NEMA 4 and 12, as well as NEMA 4x for stainless steel cabinets (depending on the component design and foam system).

The very fast-reacting Fast-Cure foam gaskets made of polyurethane for indoor and outdoor use have very short installation and tack-free times, which allow the rapid processing of the control cabinet parts up to their final assembly. This will save time and money.

With more than 30 years of practical experience of control cabinet construction, the foam gasket (tested according to DIN EN ISO 1856) shows very good recovery behavior (DVR) even after years of use. The resilience of polyurethane foam is > 95% (DVR < 5%) and that of silicone foam > 97% (DVR < 3%). This enables the frequent opening and locking of the control cabinet door while maintaining a consistently high level of impermeability.

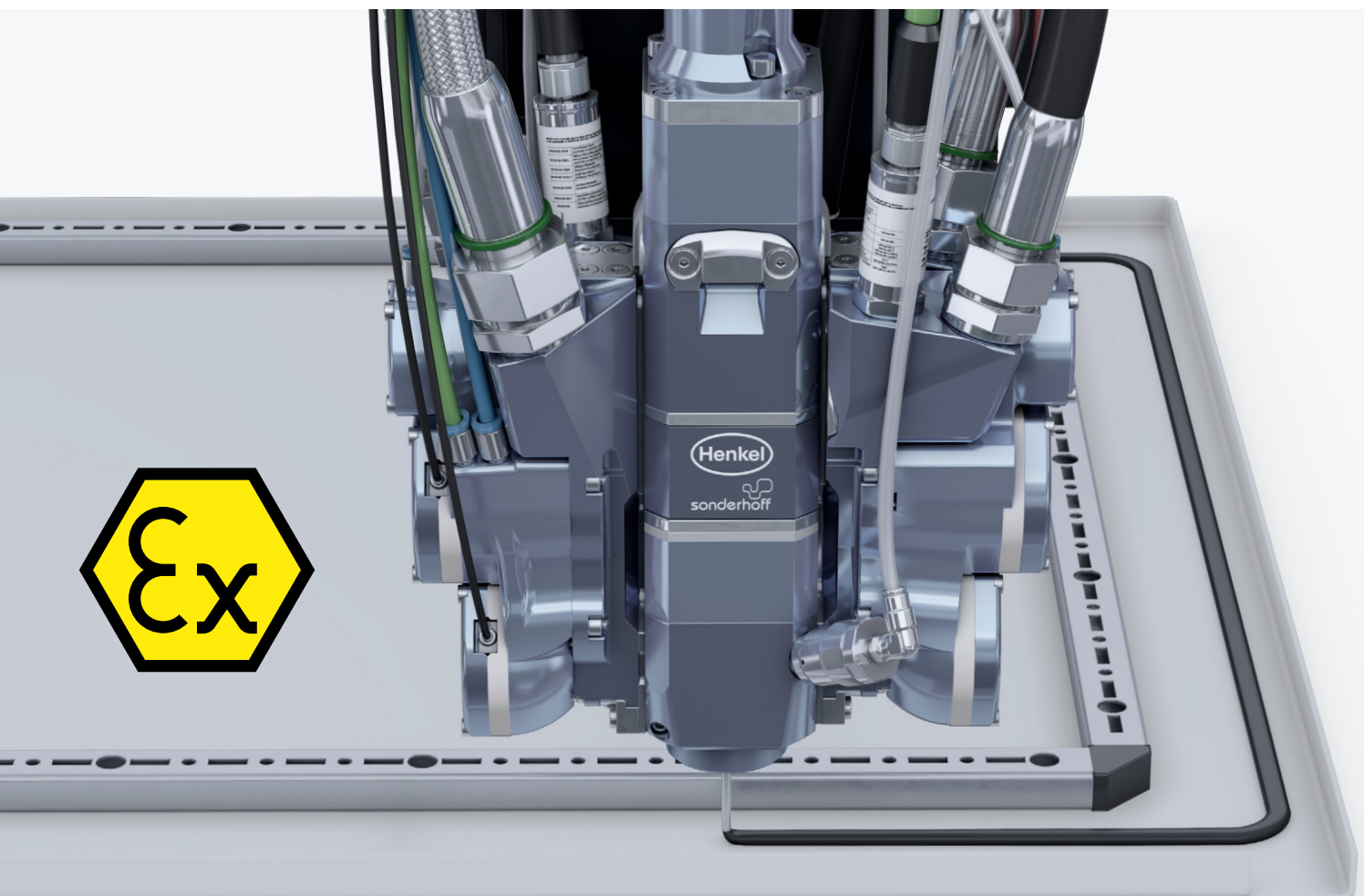

# Control cabinets and electrical distribution boxes made of plastic

## Liquid seals for very narrow grooves

The groove contours of electronic distribution boxes and the very narrow grooves of micro-distribution housings are seamlessly sealed with the sealing foams of the polyurethane-based FERMAPOR K31 or the silicone-based FERMASIL product families.

The prerequisite for the exact application of sealing foams, even in very small discharge quantities for very small housings with narrow grooves, is the contour-accurate FIPFG application with our fully automatic DM 502 mixing and dosing machine or, alternatively, with the 3E dosing cell.

From smaller to larger electrical distribution boxes, the CNC-controlled mixing head doses liquid sealant into the groove of the housing or cover with high dosing and repeat accuracy. The dosing process must be very precise, especially when dealing with very narrow grooves. After the dosing cycle, the coupling point of the room-temperature-curing foam gasket closes seamlessly and is almost invisible.

The overall design of the component and foam gasket complies with the applicable standards and protection classes (IP and NEMA) and protects the installed electronics against moisture and dust. For outdoor use, our temperature-resistant silicone foams are very suitable for protecting the electronics from extreme weather conditions.

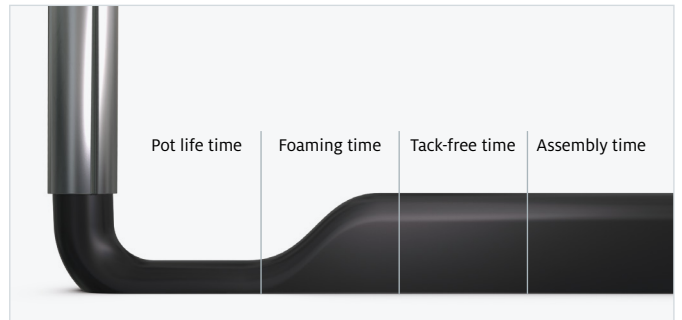

The different reaction phases of the sealing foam in the chronological sequence



	Plastic Indoor	Plastic Specific requirements
	FERMAPOR K31-A-9025-2-VP2	FERMASIL-A-91-VP2
	FERMAPOR K31-B-4	FERMASIL-B-91
<b>Mixing ratio</b>	4.5 : 1	1 : 1
<b>Pot life time</b>	33 sec.	56 sec.
<b>Tack-free time</b>	5 min.	5 min.
<b>Viscosity of the A component</b>	44,000 mPas	15,000 mPas
<b>Density</b>	0.2 g/cm <sup>3</sup>	0.3 g/cm <sup>3</sup>
<b>Hardness (Shore 00)</b>	35	52
<b>Temperature resistance</b>	from -40 to +80 °C	from -60 to +180 °C
<b>Pretreatment</b>	Plasma for e.g. PP and PE	Primer P8 or TEROSON SB450





Cross-section of a polyurethane foam bead in the groove without compression



Cross-section of a polyurethane foam bead in the groove with approx. 50% compression



Examples for electrical distribution boxes

After more than 30 years of practical experience of the sealing of electrical distribution boxes, the foam gasket (tested according to DIN EN ISO 1856) shows very good recovery behavior (DVR) even after years of use. The resilience of polyurethane foam is > 95% (DVR < 5%) and that of silicone foam > 97% (DVR < 3%). This allows the repeated opening and locking of the electrical distribution boxes for maintenance, whereby the sealing function remains permanently intact.

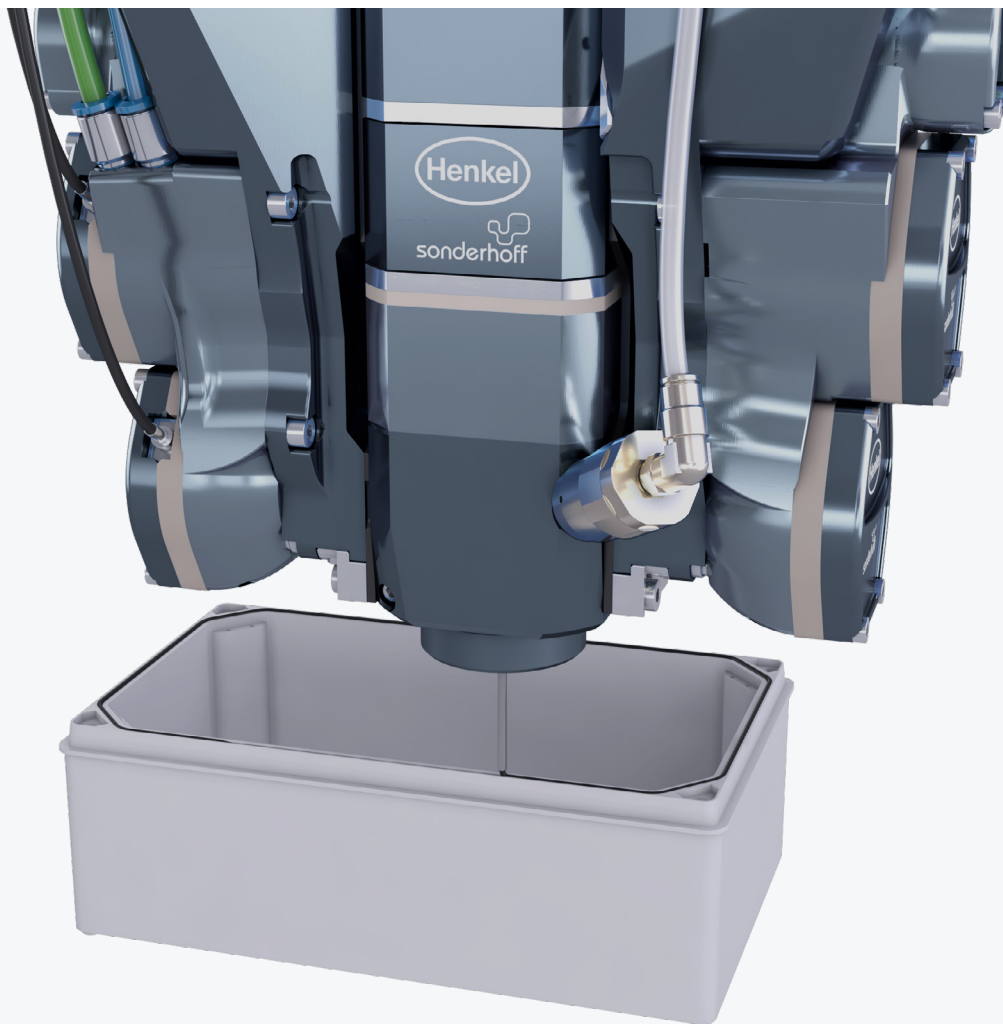

# Flexible and fully automatic – fully in line with your requirements

## DM 502 mixing and dosing system with 3-axis linear robot and a conveyor belt for the feeding of parts

Through our combination of individual material systems, customer-specific mixing and dosing machines and skilled process expertise, you receive solutions from us to meet your technical and commercial requirements.

For the construction of your control cabinets, we as process experts offer you individual consulting for the optimal integration of fully automated material application processes with the Formed-In-Place Foam Gasket (FIPFG) technology into your production. You can select different configuration and equipment options for semi-automatic or fully automatic production systems.

In the illustrated reference configuration of our DM 502 mixing and dosing system, the control cabinet parts are fed to the dosing station on a transfer belt at the cycle rate specified for your production, where they pass under the 3-axis linear robot. The components with plastic surfaces are pretreated with plasma, whereas the components with powder-coated or stainless steel surfaces are pretreated with primer. The 3-axis linear robot takes over the CNC-controlled movement of the precision mixing head above the component with contour accuracy. The primer or plasma is applied at the same time. This results in the improved adhesion of the foam gasket. We also offer the use of a primer exhaust station depending on the primer to ensure professional air cleaning on the machine.

For the sealing of the control cabinet parts and electrical distribution boxes, the CNC-controlled MK 800 PRO precision mixing head applies sealing foam to the preprogrammed contour. This process is fully automatic with a high level of dosing and repeat accuracy. The seal closes seamlessly with an almost invisible coupling point. The applied material foams and forms an elastic soft gasket with the desired foam hardness at room temperature.



Optional: Automatic **ELEVATOR drum refilling station** for the **A component** with pneumatic lift and agitator



Optional: Automatic **SUPPLY TAP drum refilling station** for low-viscosity products, e.g. isocyanates (**B component**)



**Material pressure tanks** (24 l or 44 l, single-walled or double-walled) with minimum level sensors, on a grating platform with adjustable leveling feet and drip tray



Highly dynamic **LR-HD 3-axis linear robot** for precise guidance of mixing heads for the application of polymer reaction materials. The rack-and-pinion drive with high stiffness and acceleration enables dynamic application speeds.



Optionally available: **CONTROL 2 touchscreen operating panel** (21.5") for operating the dosing system



The control electronics, safety engineering and industrial PC are installed in the **control cabinet**.



The **dosing machine cabinet** contains the components of the dosing periphery, such as the dosing pumps.

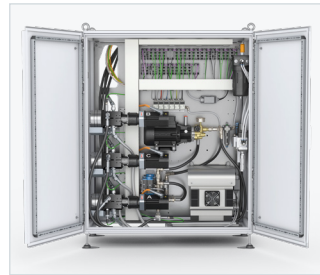

The multifunctional **MP 2 mobile panel** (10.1" WXGA TFT) enables convenient operation of the dosing system.

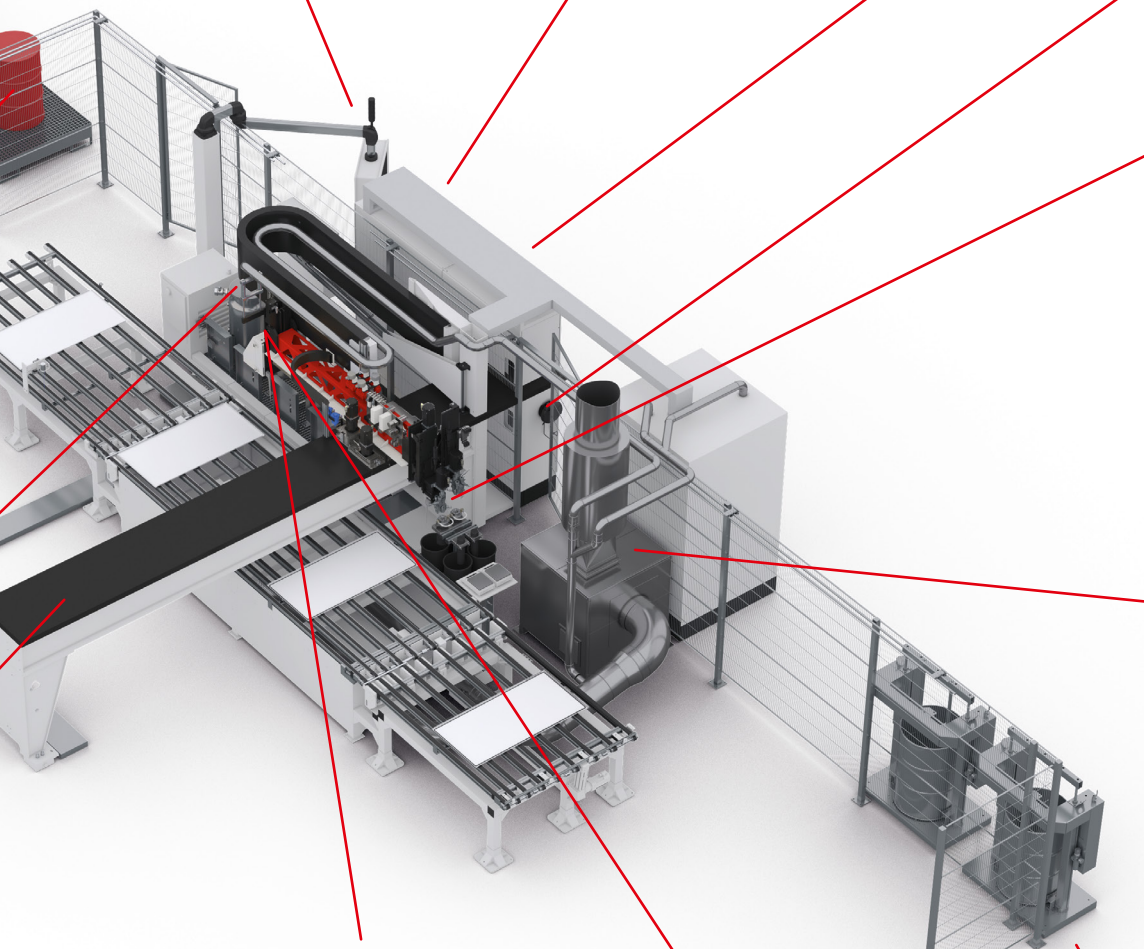

**MK 800 PRO precision mixing head** with high-pressure water rinsing

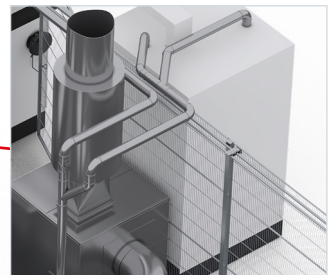

Optional: **Primer extraction station** for professional air cleaning on the machine when using solvent-based primer



**Primer application unit** – the optional **primer nozzle** mounted on the rear of the CNC Y-axis applies the primer in parallel to the seal application on powder-coated or stainless steel surfaces in the same contour.

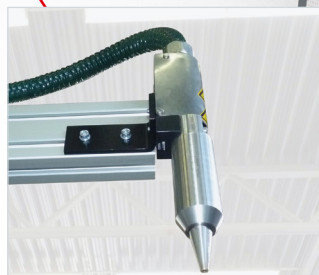
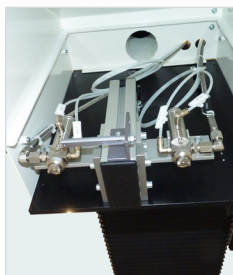

The optional **plasma nozzle** mounted on the back of the CNC Y-axis applies the plasma in parallel to the seal application on plastic surfaces in the same contour.



Optional: **FPS refilling station** – automatic drum pumping station for highly viscous materials (30 to 200-liter containers)

# The basic solution for standard applications

## Dosing cell for easy handling and high process stability

The reference configuration of the 3E dosing cell shown is a low-pressure mixing and dosing system for two components for the partially and fully-automatic application of sealing foams.

The 3E dosing cell takes up little space due to its compact design, and as a CE-compliant cell, it does not require additional safety fences or light barriers. This is a pre-programmed Plug & Work version that is delivered pre-assembled in a container. As soon as electricity, water and compressed air are connected and the material is prepared in the material pressure vessels, production can begin. The costs of installation and training courses can therefore be kept to a minimum.

The 3E dosing cell can process liquid, medium- and high-viscosity material systems based on polyurethane or silicone. The application rate is adjustable from 0.5 to 5.0 g/s. Experience shows that this is the range that can be used to represent 90% of control cabinet applications.

The optional shuttle table enables the processing of components of different sizes in one plane. Continuous operation is guaranteed by the two shuttle tables that can be moved manually in pendulum mode. For larger parts such as the control cabinet panels and doors, the two shuttle tables can be connected to form one large sliding table.

The CNC-controlled MK 825 BASIC precision mixing head for two material components applies paste-like polyurethane sealing foam with repeatable accuracy to the control cabinet parts that have a powder coating or consist of stainless steel. If stainless steel control cabinet parts should receive a primer application to improve adhesion, this can be prepared manually or with auxiliary equipment outside the dispensing system. In the case of electrical distribution boxes, our dosing technology ensures a very precise dosing application into the very narrow grooves in the housing contour.

With the CE-compliant 3E dosing cell, an immediate, safe start to production is possible, as well as efficiency-enhancing space and cost savings.

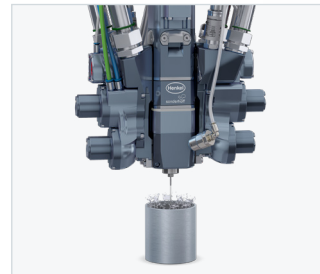

**MK 825 BASIC precision mixing head** with high-pressure water rinsing



**The material pressure tanks**, with 44 l capacity for the A component and 24 l for the B component, accommodate the typical, asymmetrical mixing ratio, which can be continuously adjusted from 10 : 1 to 1 : 2.

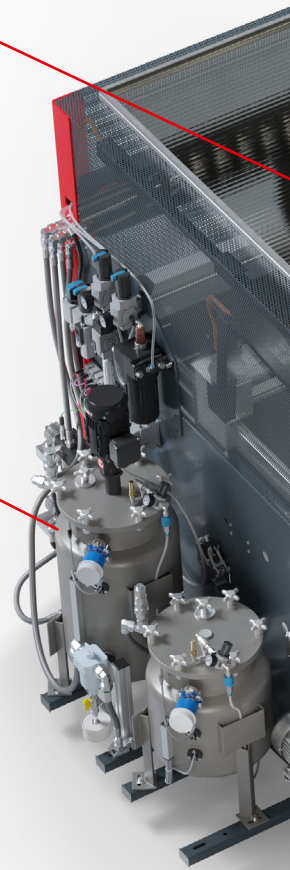

Optional: Automatic **ELEVATOR drum refilling station** for the **A component** with pneumatic lift and agitator

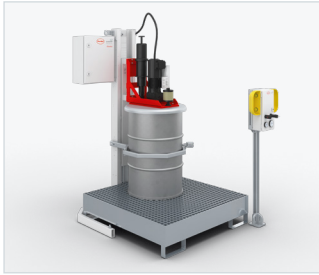

Optional: Automatic **SUPPLY TAP drum refilling station** for low-viscosity products, e.g. isocyanates (**B component**)



**Shuttle table** (optional):

Two pick-up plates to be shifted manually in pendulum mode in one plane (can be connected to one pick-up plate for large parts)

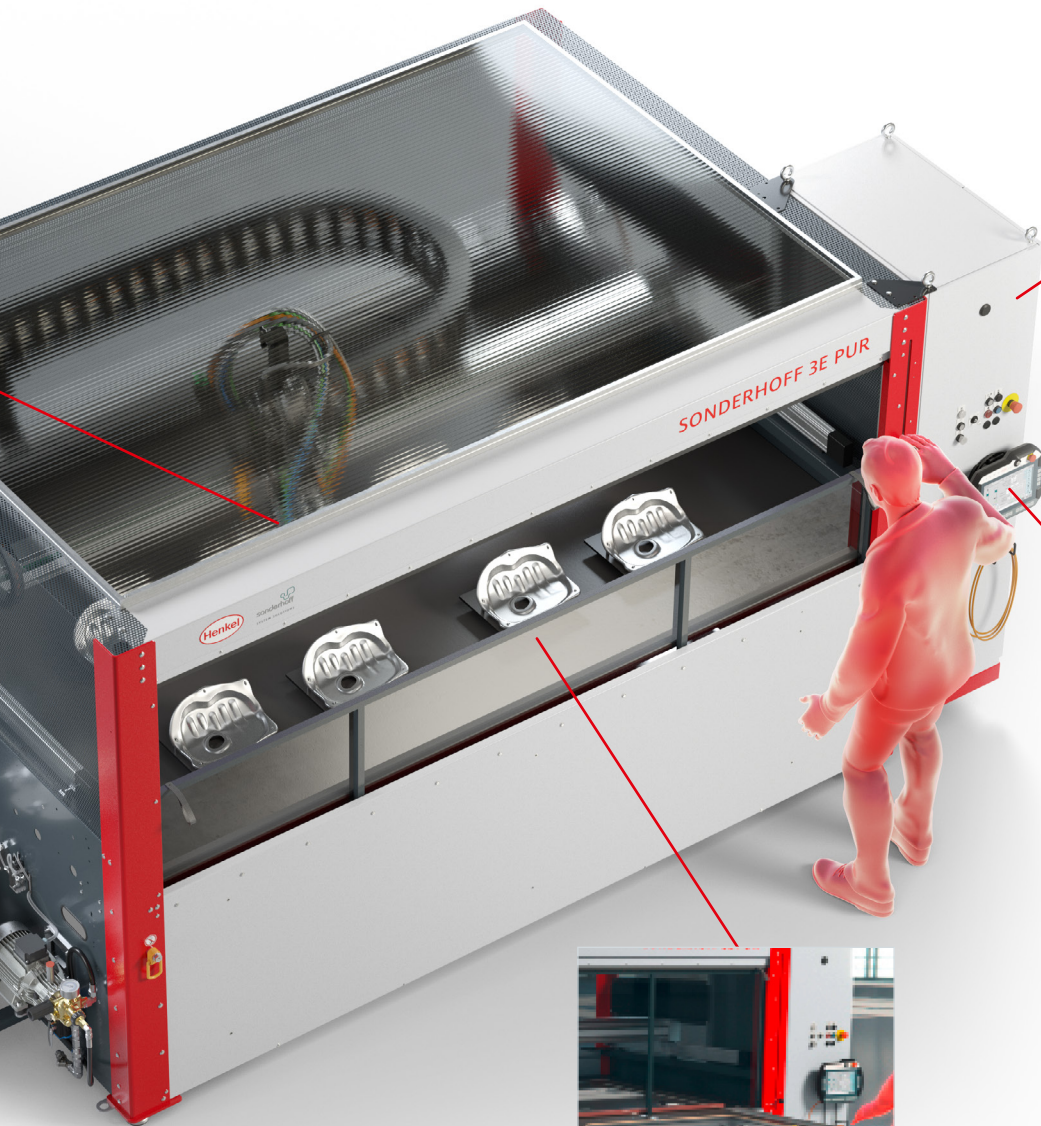
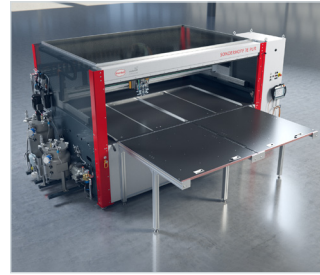

The control electronics, safety engineering and industrial PC are installed in the **control cabinet**.



The multifunction **MP 2 mobile panel** (10.1" WXGA TFT) enables convenient operation of the dosing system.

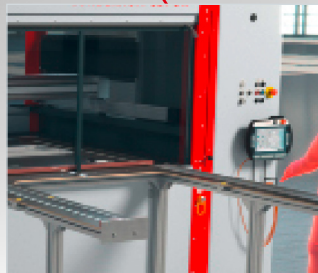

The manual **lifting door** or the high-speed door, which can be ordered as an option, safely separate the travel range of the linear robot from the operator.



sonderhoff

This is why you should use the FIPFG technology in your production process



#### Advantages of the Formed-In-Place-Foam-Gasket Technology

- › Sealing standard in many industrial sectors
- › Highly accurate material application controlled by contour robots
- › Processing and full curing at room temperature
- › Harmonized coordination of the material system and dosing system
- › Suitable for 2D and complex 3D part geometries
- › More efficient use of materials compared to punched seals
- › More cost effective compared to 2K injection molding, as there are no tooling costs
- › High degree of future viability, due to solution flexibility in a wide variety of industries & applications



### Advantages of our mixing and dosing machines

- › Combination of processes (bonding, foaming, potting)
- › High flexibility of the dosing system
- › Simple, intuitive human interface
- › Automatic material preparation incl. handling
- › High dosing and repeat accuracy
- › Short machine downtimes and cycle times
- › Fine-cell foam structure due to dynamic mixing
- › Reproducible foam quality
- › Ecological high-pressure water rinsing
- › Easy maintenance



### Advantages of our FIPFG foam gaskets

- › More cost-effective than compact systems due to lower foam density
- › Seamless seal / low visible coupling point
- › Compensation of component tolerances
- › Excellent resilience after compression
- › Multiple compression and release processes possible
- › Broad range of properties / wide variety of recipes
- › Individually adaptable formulations
- › Good form fit to the component contour
- › Resistant to moisture, dust, temperature & media
- › Flame-retardant according to UL 94
- › IP classes up to IP 68 or NEMA 4 to 6 and NEMA 12
- › Special PU foam with low VOC emissions
- › Very fast reacting PU foam (Fast-Cure)

## Perfectly coordinated solutions of material, machine and contract manufacturing

With its Sonderhoff brand, Henkel has not only acquired many years of experience in the manufacturing of tailor-made 2 component sealing systems and mixing and dosing machines, but also process expertise for very precise material application using the FIPFG (Formed-In-Place-Foam-Gasket) technology.

With the Sonderhoff portfolio, we offer our customers the advantages of a system provider from a single source and the solutions to meet your technical and commercial challenges.

With the dosing technology that is tailored to our sealing foams, we ensure efficient production processes in accordance with the requirements of fully automated series production.

If you would like to take advantage of all the benefits of the FIPFG technology for your production in a flexible, fast, and effective manner, we provide sealing solutions for your components at one of our many contract manufacturing sites worldwide without having to make your own acquisition investments. There, the spectrum ranges from the sampling of prototypes and small batch series to production scale manufacturing.

The choice is yours! You can either decide in favor of our all-inclusive package, consisting of material, machine and contract manufacturing, supported by application advice, sampling and training or you can choose the individual solutions that suit you best. We network our products and services from a single source in such a way that you receive the optimum solution for your requirements profile.

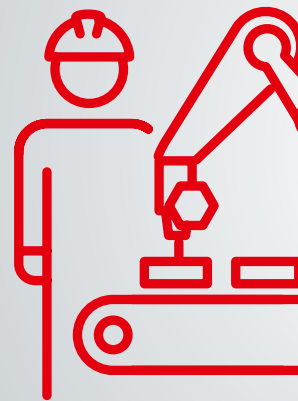

**MANUFACT**

# *Flexibility & Precision*



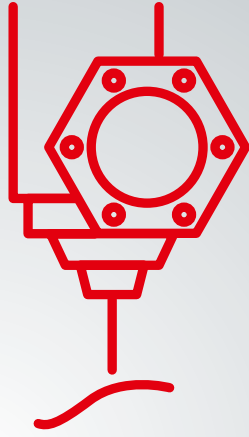

**EQUIPMENT**

# Automation Solutions

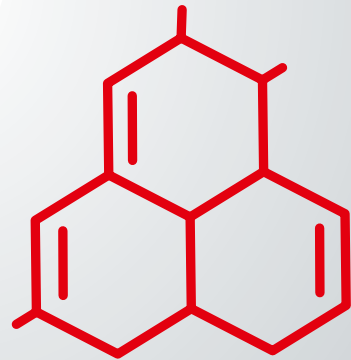

**MATERIALS**



**URING**

# Customer-specific solutions – worldwide and for many industries

The Henkel specialists for the Sonderhoff portfolio  
are available globally

**KOLO, POLAND**  
External Subcontracting Location

**DÜSSELDORF, GERMANY**  
Center of Expertise

**ELGIN, ILLINOIS, USA**  
Regional Hub

**RICHMOND (KANSAS CITY), USA**  
Regional Hub

**DORNBIRN, AUSTRIA**  
Center of Expertise

**BARCELONA, SPAIN**  
External Subcontracting Location

**OGGIONO, ITALY**  
Regional Hub

**INCHEON, KOREA**  
External Subcontracting Location

**SHANGHAI, CHINA**  
Regional Hub

**PUNE, INDIA**  
Regional Hub

**PUNE, INDIA**  
External Subcontracting Location

**SÃO PAULO, BRAZIL**  
External Subcontracting Location

*Global presence*



Every year, more than 300 million seals are manufactured in more than 50 countries using products from Henkel's Sonderhoff portfolio. At our Centers of Expertise and Regional Hubs, our specialists offer application engineering advice, e.g. selecting a suitable material system and sampling of your components, as well as project management for dosing systems and automation. You will receive training from us on how to use the FIPFG technology and we will support you with the selection of spare parts and a regular service offering. Furthermore, we will be pleased to take over parts of your production for you – from small to large series – at our subcontracting locations.

Sales staff at all other Henkel locations worldwide will also be happy to answer any questions and provide you with further information on our sealing, bonding, and potting solutions. We look forward to hearing from you.



**Henkel AG & Co. KGaA**

Henkelstraße 67  
40589 Düsseldorf  
Germany  
Tel.: +49 211 797-0  
Fax: +49 211 798 4008

[www.henkel.com](http://www.henkel.com)  
[www.sonderhoff.com](http://www.sonderhoff.com)

Get in contact with us



The description of the possible fields of use of our products as well as the technical data and values only have a general character and do not mean that a certain product can be used under all conditions in the respective field of use. In this respect, the stated field of use is not a binding specification or usage provision. Due to the great number of environment variables and their influences (e.g. temperature, test specimens, size, interaction with substrates, influence of machines, or the like) you as our customer must check whether the product is suitable for your specific field of use. We will be pleased to assist and advise you in this respect. Except as otherwise noted, all marks used above are trademarks and/or registered trademarks of Henkel and its affiliates in the U.S., Germany and elsewhere.

© 8.2024 Henkel AG & Co. KGaA. All rights reserved