

SEALING, BONDING AND FOAM-IN-PLACE MOLDING OF AIR FILTERS

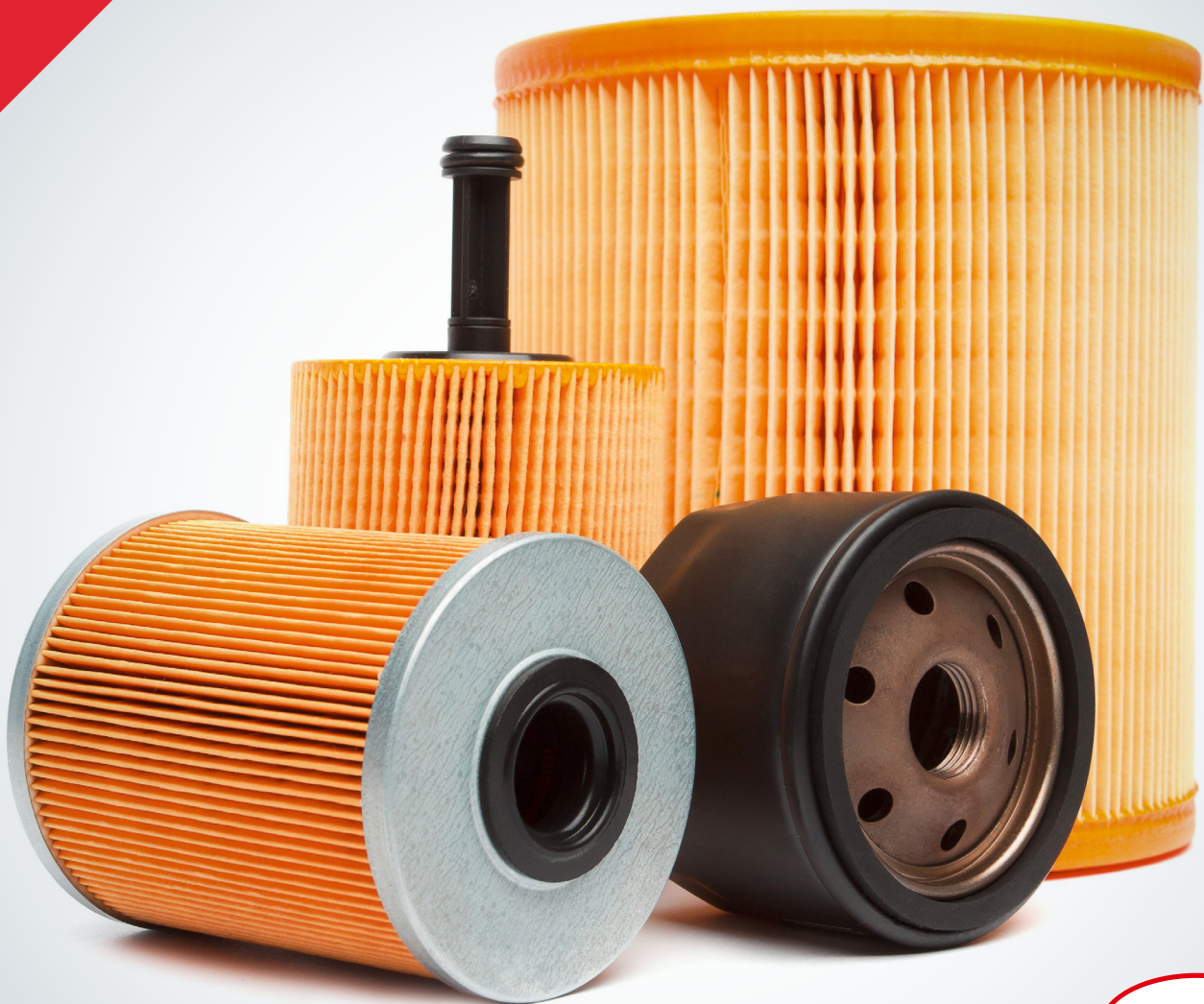

So that only what should get through actually gets through

High performance filter systems play a hidden but important role in our modern world. These include systems for industrial plants, hospitals and power stations which often have to deliver consistently clean air under tough operation conditions. Reliable air conditioning technology with purified air ensures the smooth operation of technical facilities in the research, IT infrastructure and production sectors.

Air conditioning systems provide indoor spaces with filtered fresh air, creating a healthy indoor climate. This is important for our personal well-being, as well as compliance with regulations for ensuring air quality in workplaces, offices and production facilities. It is a matter of constantly exchanging air in rooms and removing humidity, odors, smoke, carbon dioxide, heat accumulation, dust or airborne bacteria.

To ensure that the air filters can perform these tasks for air conditioning in the office, clean rooms in laboratories and operating theaters, optimal bonding of the filter pack into the frame is essential. The fresh air pumped in to be cleaned flows exclusively through the filter medium and requires a leak-free sealing of the filter frame in its installed state.

Are you looking for a system solution consisting of sealing material, dosing system and process automation from a single supplier?

We offer you a perfectly coordinated sealing and bonding solution, which will optimally and reliably enable you to meet your various technical and economic requirements. Irrespective of whether they are compact; pocket; cartridge or panel filters; filter end caps or filter cassettes, leading manufacturers have been relying on our expertise for decades. In each case they have used out sealing and bonding solutions to implement the best possible filter production process.

Do you need an automation system that adapts to your production requirements?

The modular design of our mixing and dosing systems allows flexible use, with excellent integration into existing production concepts. Our CNC-controlled mixing and dosing systems offer high levels of repeatability and dosing accuracy and are highly efficient.

Henkel's technology solutions are designed to optimize the quality, reliability and safety of your filter products in use. Henkel's molding and sealing foams and adhesive sealants ensure that the filters deliver what they promise: clean air.

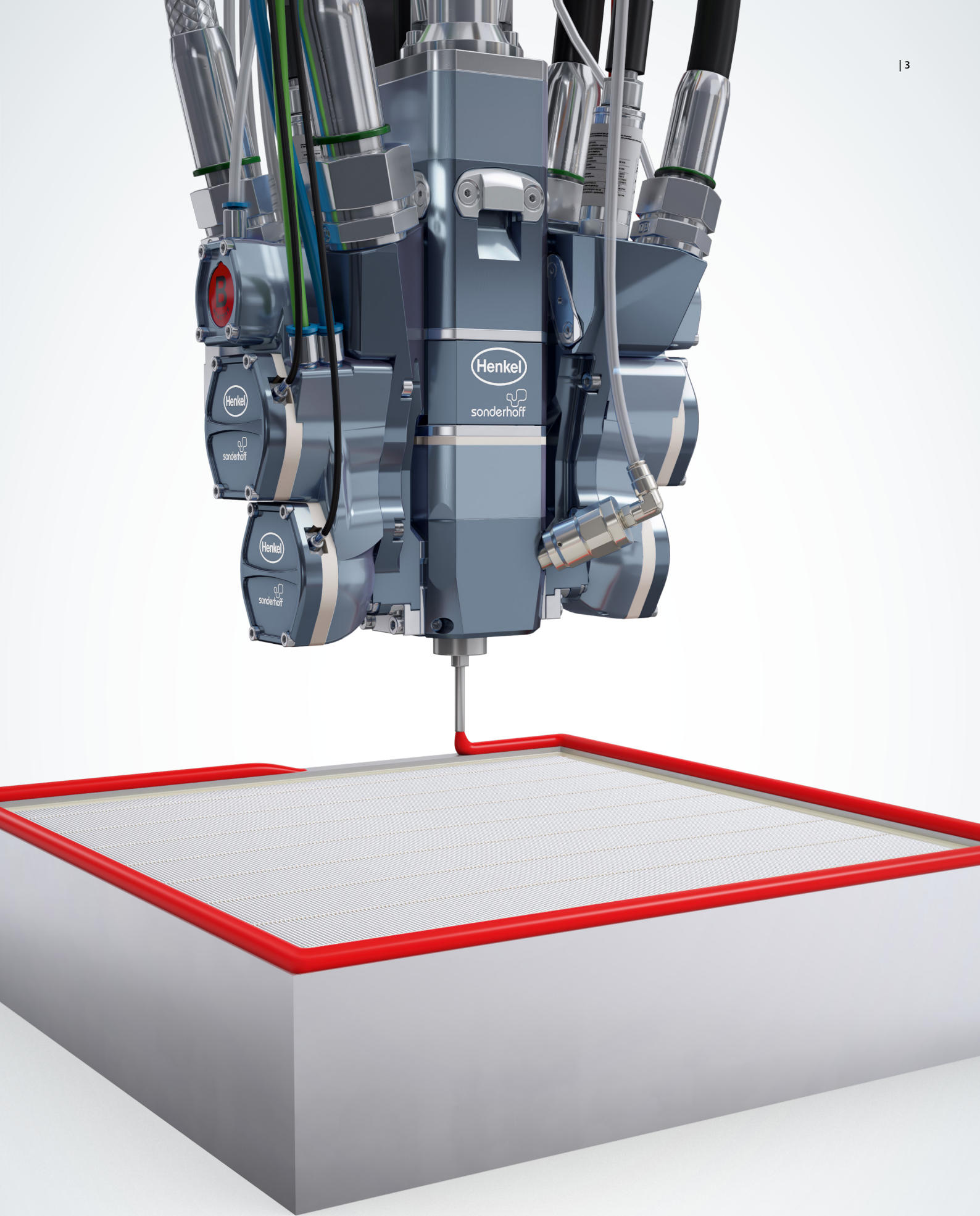

Air filters with foam-in-place gasket

We carry out developments individually for your specific requirements

A wide range of technically reliable solutions for automotive air filters can be achieved by foam-in-place gaskets with the reference material FERMAPOR-K31-A-9846-12-VP2 and B-81 (B-component) made of 2-component polyurethane foam. By using an open mold into which the sealing material is introduced, square air filter frames can be produced, or even round shapes like e.g. the end caps on radial filters for commercial vehicles.

In this process, the filter medium is inserted into a prefabricated forming tool coated with release agent. The CNC-controlled MK 800 PRO precision mixing head of the DM 502 mixing and dosing machine fills the contour of the mold with the dynamically mixed 2-component polyurethane sealing foam. Depending on the process, the filter pack is inserted into the mold immediately afterwards, or has already been inserted before injection of the foam. The injected sealing material foams, expanding to several times its original volume and fills the mold contour with a positive fit. The polyurethane foam bonds to the outer edges of the filter pack to form a foam-in-place frame gasket.

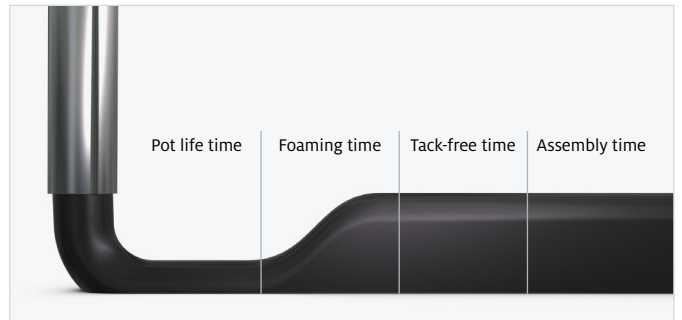

The different reaction phases of the sealing foam in the chronological sequence

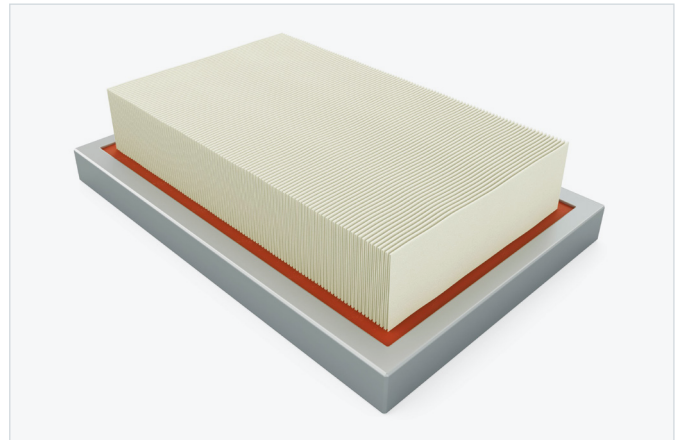

The polyurethane foam completely fills the mold contour, and bonds to the outer edges of the filter pack to form a foam-in-place frame gasket.

	Industrial air filters with foam-in-place frames / end caps
FERMAPOR K31-	A-9846-12-VP2
	B-81
Mixing ratio	3 : 1
Pot life time	35 sec.
Tack-free time	7 min.
Viscosity of the A component	4,000 mPas
Density of the foam	0.26 g/cm ³
Hardness (Shore 00)	70
Temperature resistance	from -40 to +80 °C



Radial air filter with end caps provided with a foam-in-place polyurethane gasket

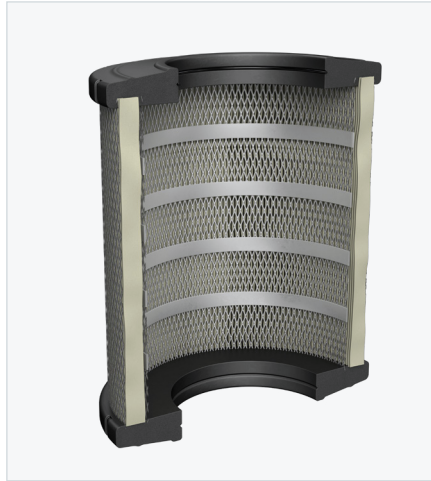

Cross-section of radial air filter showing the connection of filter pack and metal support frame to the PU foam.

After the material has cured, the air filter with the foam-in-place gasket can be removed from the mold for further processing in the manufacturing process. To accelerate this curing process, the mold with the filter pack is run through an annealing oven shortly after injection of the material. The heat inside the oven cures the material faster.

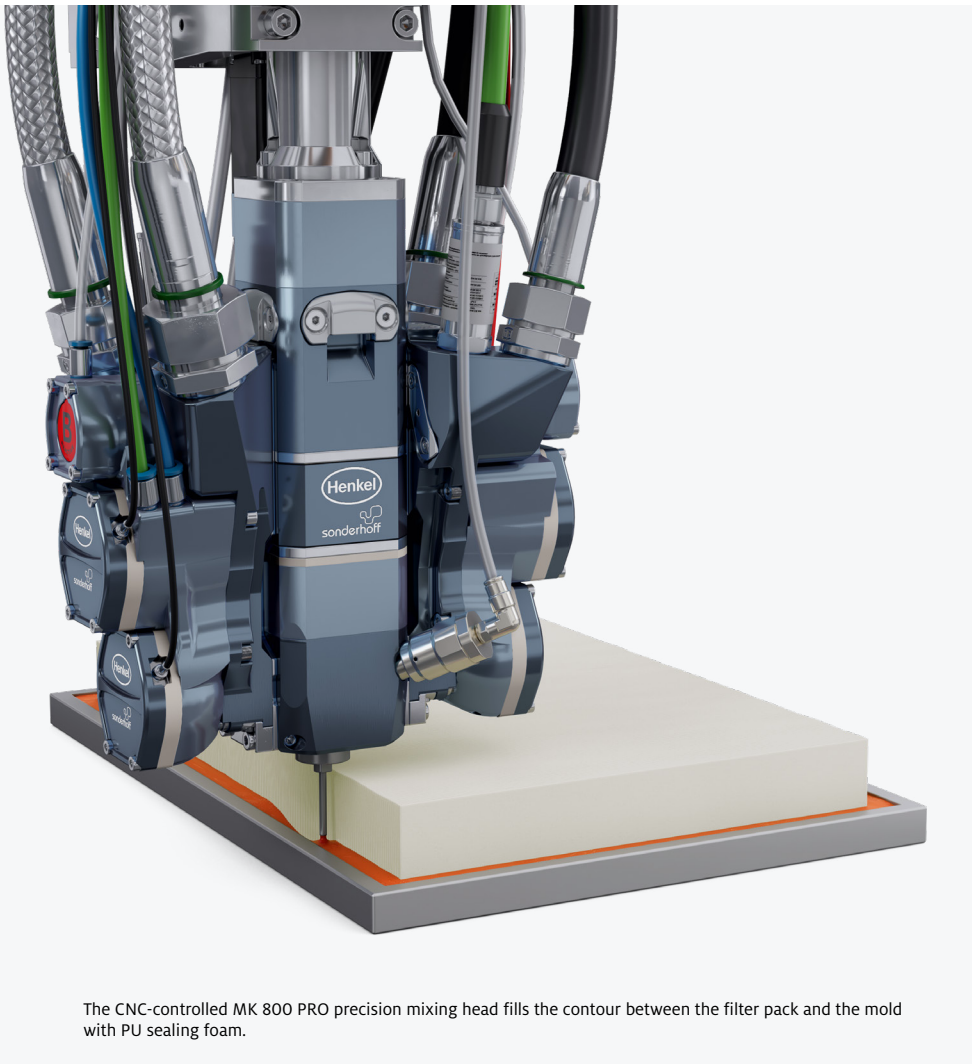

The CNC-controlled MK 800 PRO precision mixing head fills the contour between the filter pack and the mold with PU sealing foam.

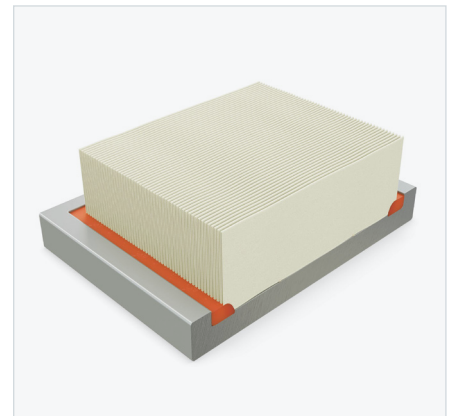

Cross-section of the air filter inside the mold showing the connection of the filter pack to the PU foam.



Air filter removed from the mold with PU-foamed frame gasket

Flexible and fully automatic – fully in line with your requirements

DM 502 mixing and dosing system with 3-axis linear robot for foam-in-place molding of air filter frames and the transfer belt for the feeding of parts

In the reference configuration of the DM 502 mixing and dosing system as shown, the air filters placed in a mold are guided to the dosing station on a transfer belt arranged below the 3-axis linear robot. The highly efficient 3-axis linear robot handles the contour-accurate CNC-controlled movement of the precision mixing head above the part to be processed.

Alternatively, the DM 502 can also be used as a sliding table system with the LR-HD 3-axis linear robot and WT 1-LEVEL shuttle table. Parts are picked up and processed here in continuous shuttle mode, operating in a single plane.

The CNC-controlled MK 800 PRO precision mixing head of the DM 502 mixing and dosing machine moves along the contour of the air filter, which has been inserted into the mold, and applies the 2-component FERMAPOR K31 polyurethane sealing foam into the circumferential mold cavity. The injected material foams expanding to several times its original volume and fills the mold with a positive fit. After curing, the air filter with the foam-in-place gasket is removed from the mold for further processing in the manufacturing process.

In series production for large unit numbers, automatic refilling stations are generally used. These use agitators to ensure the optimal preparation and homogeneous consistency of the material. The refilling stations ensure that material is supplied continuously to the material pressure tanks, allowing fully automatic production processes. Capacitive sensors on the material pressure tanks monitor the filling level and control refilling. This means that the production process is not interrupted in the event of a material change.

The fail-safe DM 502 mixing and dosing machine can be operated easily and intuitively without much training. All dosing and process data are recorded automatically, allowing tracking and evaluation by the machine operator via the CONTROL 2 operating panel.

In all solutions, our main focus is on extremely reliable plant engineering, minimized maintenance times and consistent dosing quality.



Optionally available: **CONTROL 2 touchscreen operating panel (21.5")** for operating the dosing system



Separately installed **material pressure tanks (24 l or 44 l, single-walled or double-walled)** with minimum level sensors, on a grating platform with adjustable leveling feet and drip tray



Highly dynamic **LR-HD 3-axis linear robot** for precise guidance of mixing heads for the application of polymer reaction materials. The rack-and-pinion drive with high stiffness and acceleration enables dynamic application speeds.

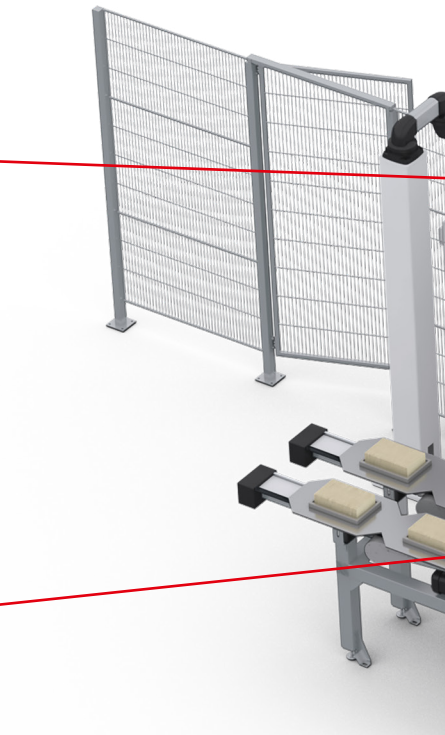

Optional: Highly efficient **LR-HE plus 3-axis linear robot** for precise guidance of mixing heads for the application of polymer reaction materials. The Omega toothed belt drive enables high application speeds for components with medium and large radii.

The **dosing machine cabinet** contains the components of the dosing periphery, e.g. the dosing pumps.

The control electronics, safety engineering and industrial PC are installed in the **control cabinet**.

Alternative machine configuration: DM 502 with MK 800 PRO with LR-HD linear robot and WT 1-LEVEL shuttle table

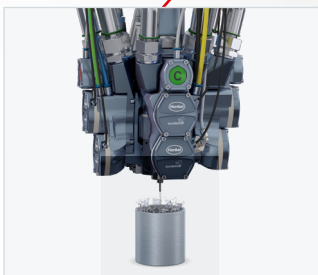
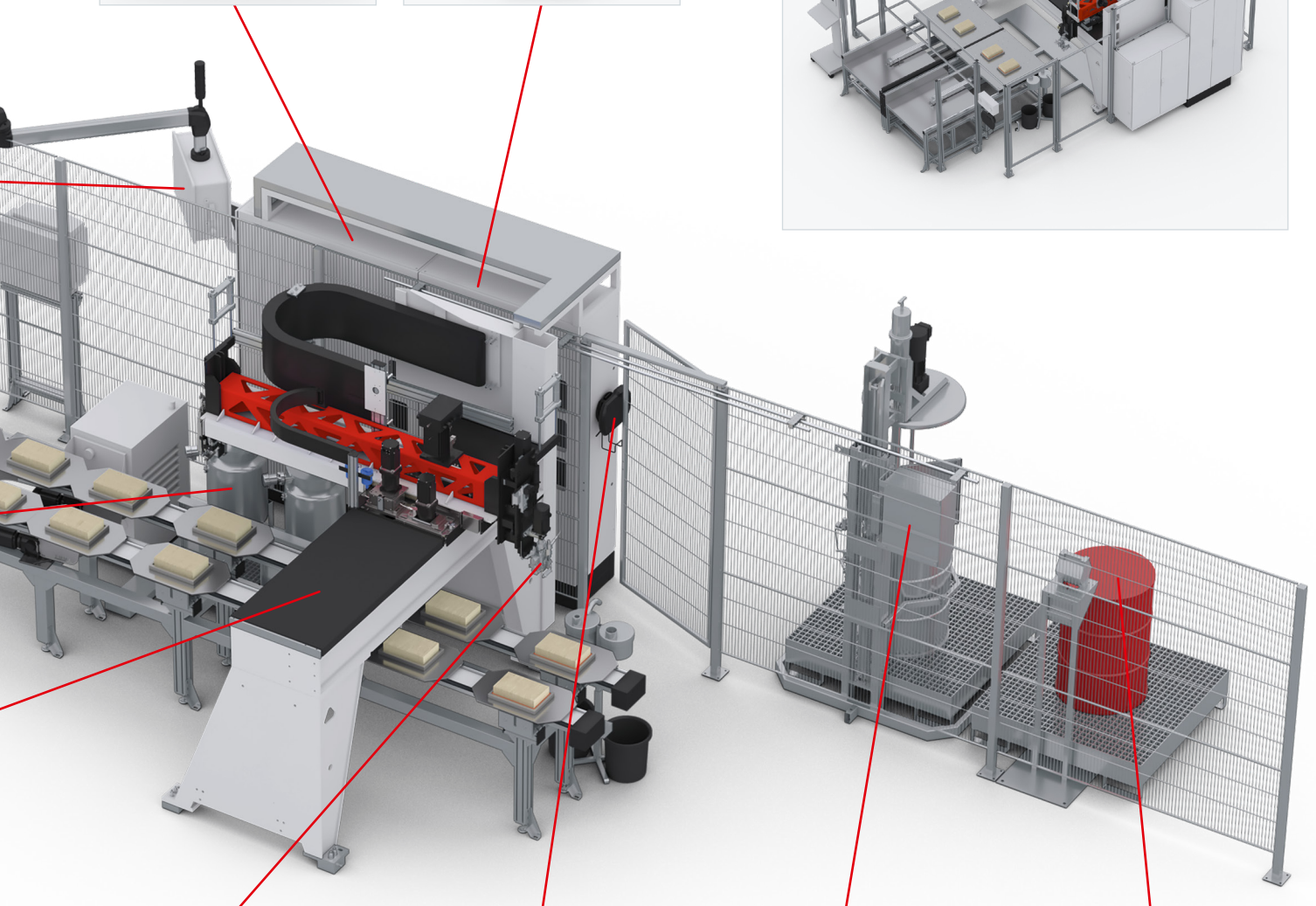
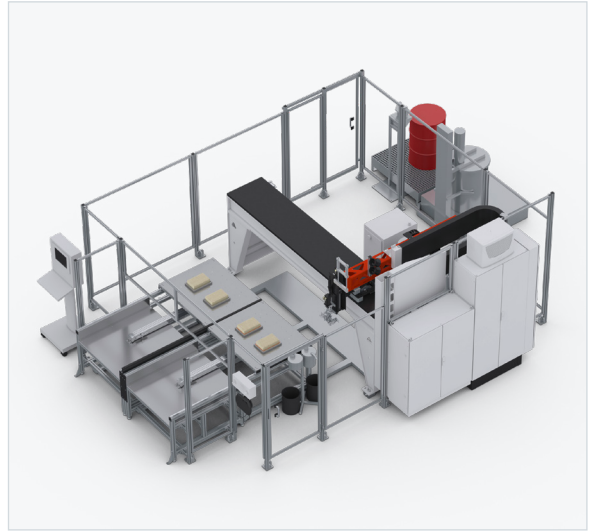
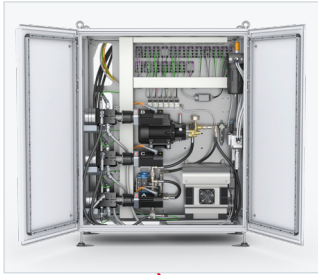

MK 800 PRO precision mixing head with high-pressure water rinsing



The multifunctional **MP 2 mobile panel** (10.1" WXGA TFT) enables convenient operation of the dosing system.



Optional: Automatic **ELEVATOR drum refilling station** for the **A component** with pneumatic lift and agitator



Optional: Automatic **SUPPLY TAB drum refilling station** for low-viscosity products, e.g. isocyanate (**B component**)

Bespoke solutions to seal panel filter frames

Differently soft polyurethane sealing foams for low closing forces and compensation of component tolerances

The reference materials presented here have been used by leading manufacturers of panel air filters for many years, and are tried and tested. The 2-component polyurethane sealing foams of the FERMAPOR K31 product family are available for this purpose in different viscosities, ranging from liquid for the frame groove to thixotropic for flat or three-dimensional application surfaces. The thixotropic sealing foams are available in a soft and also slightly harder versions.

Alternatively, we can also customize our material systems to meet your component requirements and specifications. Influencing factors include pot life until start of foaming, curing time, and the viscosity, hardness and adhesion properties. Thanks to the mixed-cell foam structure, closing forces of the foam gasket are low during installation of the panel filters.

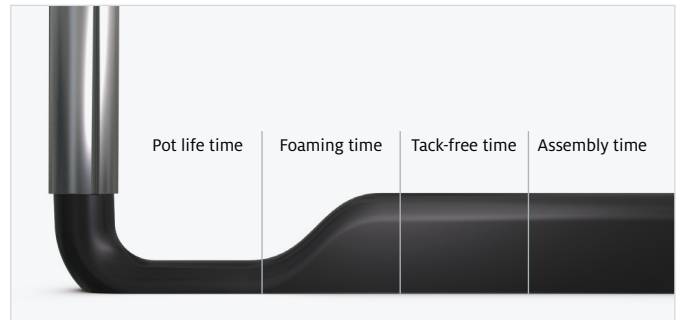

The different reaction phases of the sealing foam in the chronological sequence

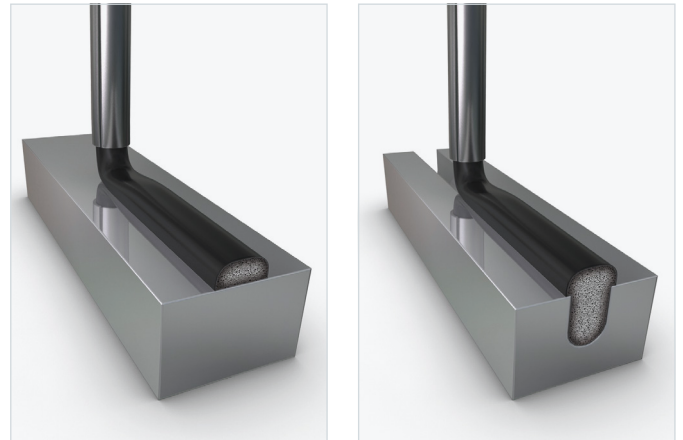

Panel air filter with foam-in-place PU frame gasket	thixotropic (soft version)	thixotropic (harder version)	liquid / soft for frame groove
FERMAPOR K31-	A-9025-7-VP	A-5065-1-G-MX	A-9808
	B-N	B-N	B-4
Mixing ratio	4.5 : 1	5.5 : 1	4.5 : 1
Pot life time	27 sec.	39 sec.	55 sec.
Tack-free time	5 min.	4 min.	6 min.
Viscosity of the A component	52,000 mPas	65,000 mPas	1,200 mPas
Density of the foam	0.18 g/cm ³	0.24 g/cm ³	0.29 g/cm ³
Hardness (Shore 00)	35	48	26
Temperature resistance	from -40 to +80 °C	from -40 to +80 °C	from -40 to +80 °C

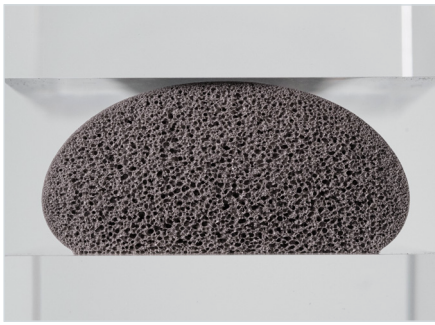

Cross-section of a polyurethane foam bead – uncompressed



Cross-section of a polyurethane foam bead with 50% compression



Cross-section of a polyurethane foam bead in groove uncompressed

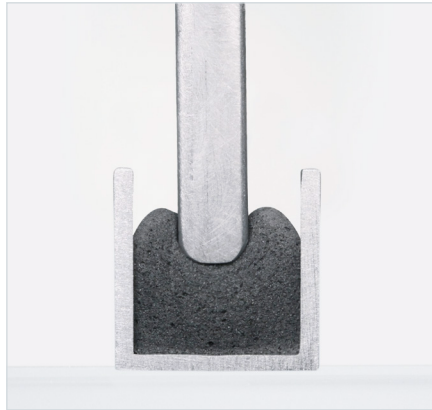

Cross-section of a polyurethane foam bead in the groove with approx. 50% compression

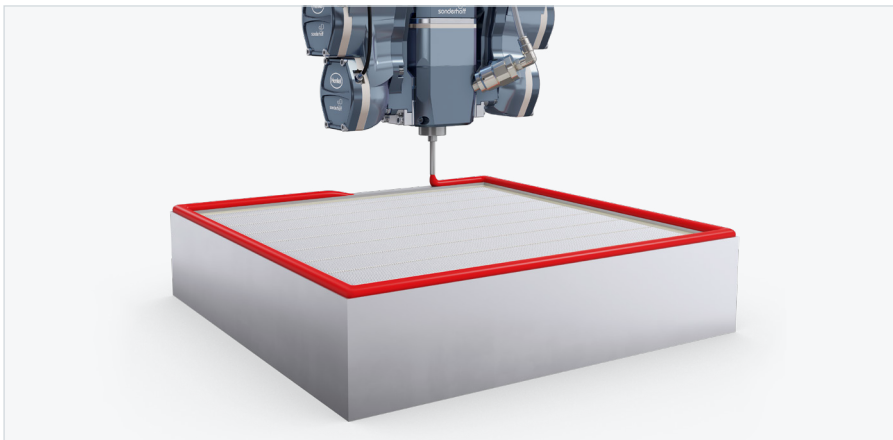

PU foam application with CNC-controlled MK 800 PRO precision mixing head on flat panel filter frame

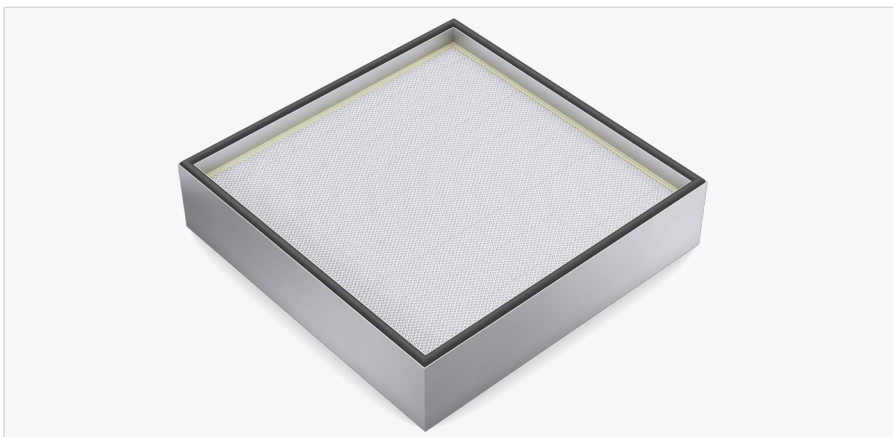

Panel air filter with PU foam gasket in the frame groove

When installing the air filter in the air-conditioning system, for example, the tongue-and-groove design ensures that the filter frame with foam gasket is firmly connected to the counterpart on the filter seat. The foam gasket compensates for component tolerances during sealing and thus prevents air drawn in from outside from flowing past the filter unfiltered due to possible leakage.

The excellent shape recovery characteristics of the FERMAPOR K31 polyurethane foam gasket allow repeated installation and removal of the air filters of air conditioning systems for maintenance purposes without reduction or even loss of the sealing effect (tested according to DIN EN ISO 1856).

Gel sealing of panel filter frames

Polyurethane gel with self-healing effect and airtight closure

The reference material presented here is a 2-component polyurethane gel FERMADUR A-112-VP3 with the crosslinker FERMADUR B-50-NM as B-component. It has been used for sealing panel filter frames by leading manufacturers of air filters for many years, and is tried and tested. Alternatively, we can also customize our material systems to meet your specific component requirements.

The requirements for sealing material used in panel filters for air conditioning systems in hospitals, and clean rooms for microchip manufacturing, are challenging. State-of-the-art production processes, such as those in the pharmaceutical and microelectronics industries, also require high levels of air purity. The air filters required for clean rooms, from HEPA (High Efficiency Particulate Air) to super ULPA (Ultra-Low Penetration Air) filters, not only need to be manufactured to the highest quality standards but also require a leak-free fit when installed. This is ensured by FERMADUR gel seals.

With the help of the very precise DM 502 mixing and dosing machine, the gel seals are injected bubble-free into the groove of the filter frames. They are also available in low Shore hardness versions. The high aging resistance of the gel seals excludes the possibility of leakage, or of the filter seals losing tension over time.

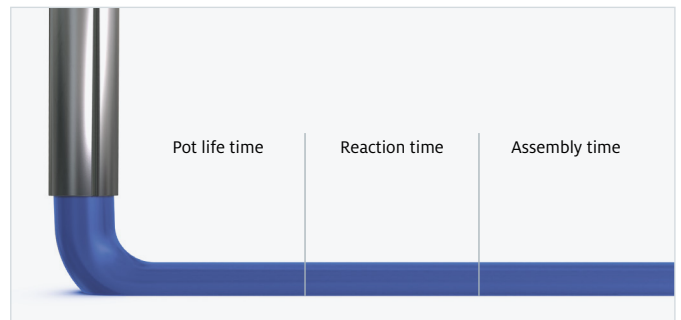

The different reaction phases of the polyurethane gel in chronological order

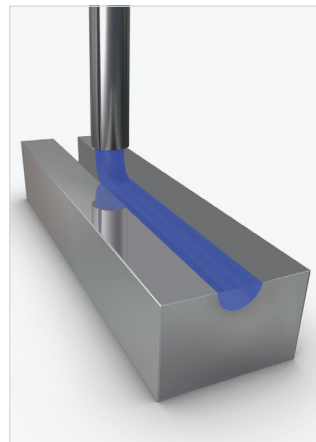

Gel dosing, shallow groove

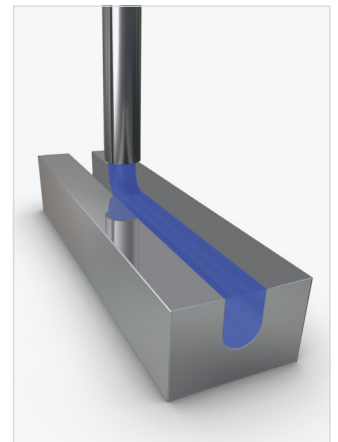

Gel dosing, deep groove

Panel air filter frame with PU gel seal in the groove	Polyurethane gel
FERMADUR	A-112-VP3
	B-50-NM
Mixing ratio	6 : 1
Pot life time	200 sec.
Tack-free time	permanently gel-like
Viscosity of the A component	200 mPas
Density of the foam	1.02 g/cm ³
Hardness (Shore 00)	15
Temperature resistance	from -40 to +80 °C



Cross-section:
Polyurethane gel in groove



Cross-section:
Tongue immersed in polyurethane gel seal

During installation in e.g. an air-conditioning system using the tongue-and-groove principle, the panel filter frame is installed with the tongue of the counterpart immersed in the gel seal. This creates an airtight seal. The decisive factor is that when the filter frame is removed for maintenance purposes, the place where the tongue was immersed in the gel will reliably close again of its own accord, thanks to the self-healing effect. The filter seat is thus hermetically sealed, and all air flows through the filter without air impurities being able to get past the filter into the conditioned room air.

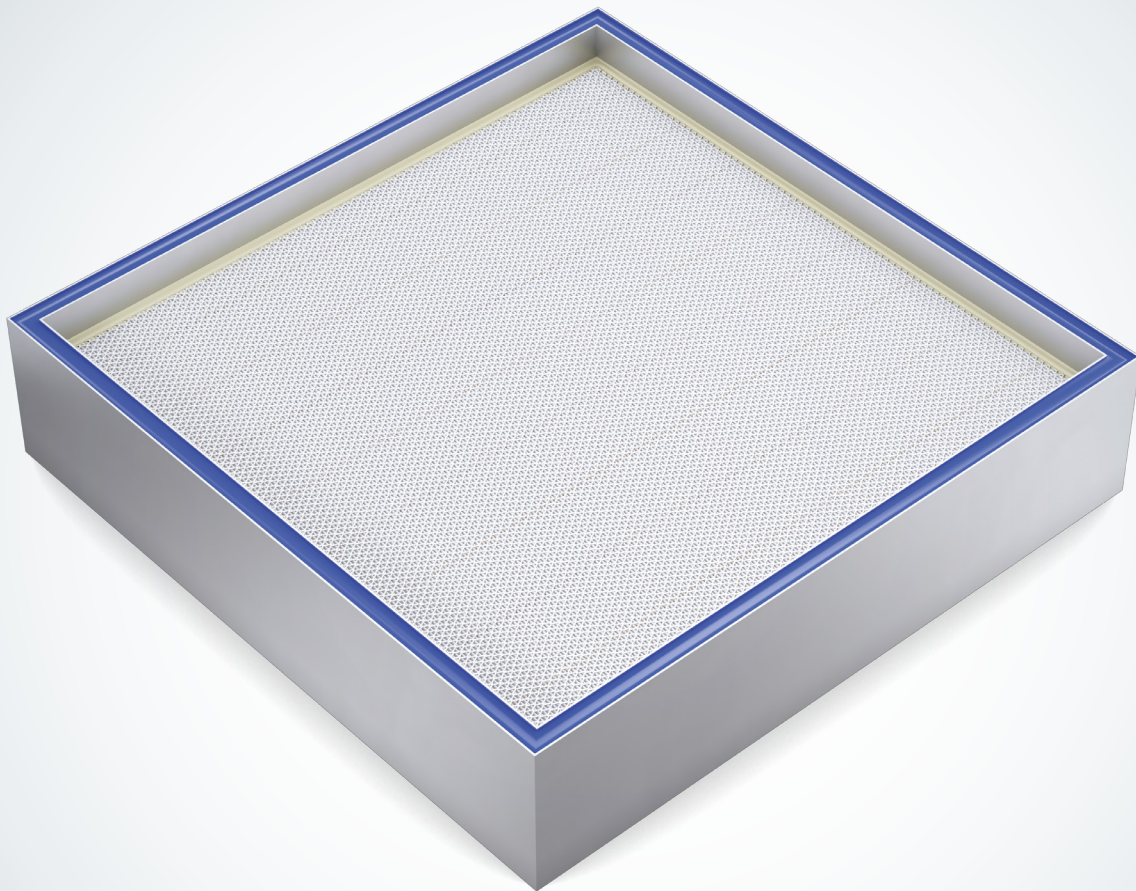

Panel air filter with PU gel seal in the groove of the frame

Flexible and fully automatic – fully in line with your requirements

Mixing and dosing system DM 502 with 3-axis linear robot for the sealing of panel filter frames using sealing foam or gel seals

In the reference configuration of the DM 502 mixing and dosing system shown here, the filter frames are fed to the dosing station on a transfer belt passing under the 3-axis linear robot. The LR-HD 3-axis linear robot handles the contour-accurate CNC-controlled movement of the precision mixing head above the component. Alternatively, the DM 502 can also be used as a sliding table system with the LR-HD linear robot and the WT 1-LEVEL shuttle table.

The MK 800 PRO precision mixing head of the DM 502 applies the polyurethane sealing foam to the frame contour fully automatically using the FIPFG process with high dosing and repeat accuracy. For frame grooves, the liquid version FERMAPOR K31-A-9808 is used; for filter frames without a groove, the thixotropic sealing foams FERMAPOR K31-A-9025-7-VP (soft version) or FERMAPOR K31-A-5065-1-G-MX (somewhat harder version) are used.

For a comprehensive filter product portfolio, the DM 503 dosing system can alternatively be used, which is designed for three components. This dosing system can produce panel filters with a single seal on a flat surface, as well as panel filters with a groove design and using two different sealing systems.

The applied material foams, expanding to several times its original volume, and forms an elastic soft foam gasket with the desired foam hardness at room temperature. After the dosing cycle, the coupling point of the foam gasket closes seamlessly and is almost invisible. It achieves consistently tight sealing through uniform compression over the entire contour of the panel filter frame.

The decisive factors for the low water absorption of the foam gasket in its installed state are the fine-cell foam structure and the degree of compression.

The fail-safe DM 502 mixing and dosing machine can be operated easily and intuitively without much training. The dosing and process data are recorded, and can thus be tracked and evaluated by the machine operator via the CONTROL 2 operating panel.



Optionally available: **CONTROL 2 touchscreen operating panel** (21.5") for operating the dosing system



Separately installed **material pressure tanks** (24 l or 44 l, single-walled or double-walled) with minimum level sensors, on a grating platform with adjustable leveling feet and drip tray



Highly dynamic **LR-HD 3-axis linear robot** for precise guidance of mixing heads for the application of polymer reaction materials. The rack-and-pinion drive with high stiffness and acceleration enables dynamic application speeds.



Optional: Highly efficient **LR-HE plus 3-axis linear robot** for precise guidance of mixing heads for the application of polymer reaction materials. The Omega toothed belt drive enables high application speeds for components with medium and large radii.

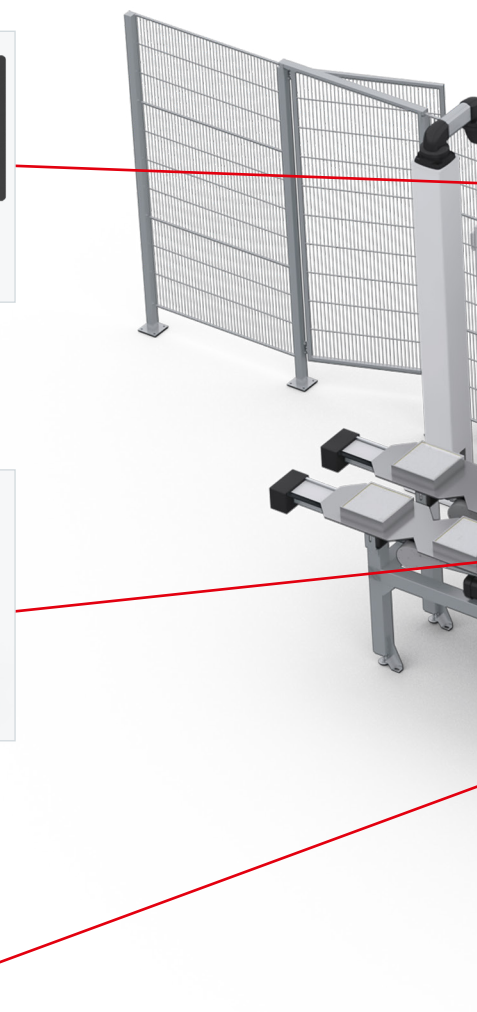

The **dosing machine cabinet** contains the components of the dosing periphery, e.g. the dosing pumps.

The control electronics, safety engineering and industrial PC are installed in the **control cabinet**.

Alternative machine configuration: DM 502 with MK 800 PRO with LR-HD linear robot and WT 1-LEVEL shuttle table

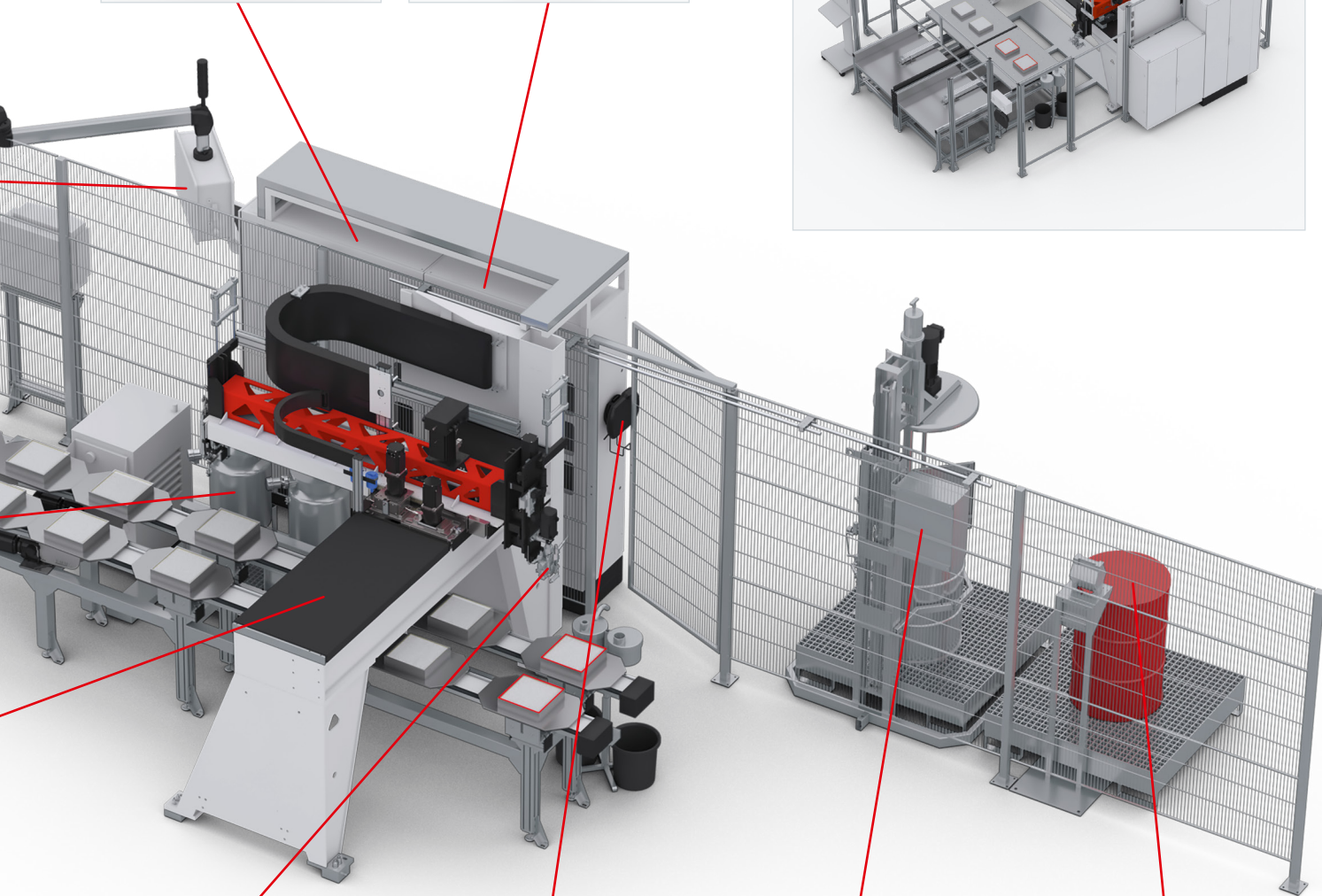
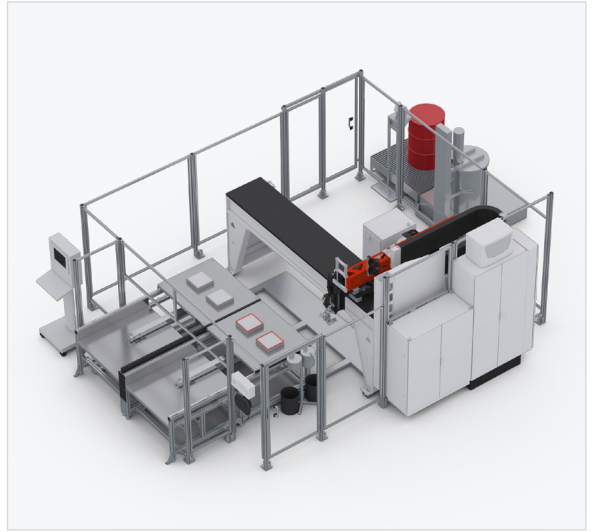
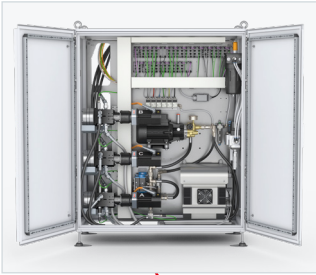

MK 800 PRO precision mixing head with high-pressure water rinsing



The multifunctional **MP 2 mobile panel** (10.1" WXGA TFT) enables convenient operation of the dosing system.



Optional: Automatic **ELEVATOR drum refilling station** for the **A component** with pneumatic lift and agitator



Optional: Automatic **SUPPLY TAB drum refilling station** for low-viscosity products, e.g. isocyanate (**B component**)

Bespoke solutions for bonding filter packs into frames or end caps

We carry out developments individually for your specific requirements

For purposes of bonding filter packs into filter frames or to the end caps, the compact, polyurethane-based 2-component adhesive sealant systems FERMADUR A-46D05-1-W or FERMADUR A-196-9-VP1 are available, each with the B-component FERMADUR-B-N. The reference materials presented here have been used by the leading manufacturers of air filters for many years, and are tried and tested. Alternatively, whenever possible, we can also customize our material systems to meet your specific requirements.

The bonding process requires precise mixing and dosing of the adhesive components, maintaining a precisely defined mixing ratio. For this purpose, we offer you our precision mixing and dosing machines, whose dosing accuracy throughout the process ensures optimal processing of the polyurethane adhesives.

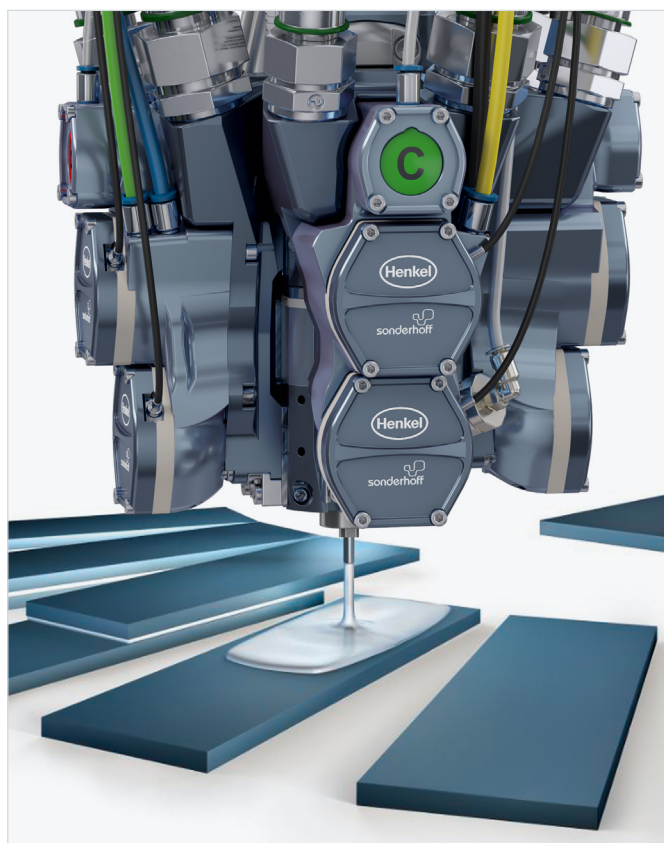

Full-surface bonding with FERMADUR adhesive sealants

Air Filtration	End cap and frame bonding	Frame bonding
FERMADUR	A-46D05-1-W	A-196-9-VP1
	B-N	B-N
Mixing ratio	3 : 1	2.8 : 1
Pot life time	150 sec.	67 sec.
Tack-free time	8 min.	3 min.
Viscosity of the A component	5,000 mPas	6,100 mPas
Density of the foam	1.25 g/cm ³	1.27 g/cm ³
Hardness	50 (Shore 00)	87 (Shore A)
Temperature resistance	from -40 to +80 °C	from -40 to +80 °C

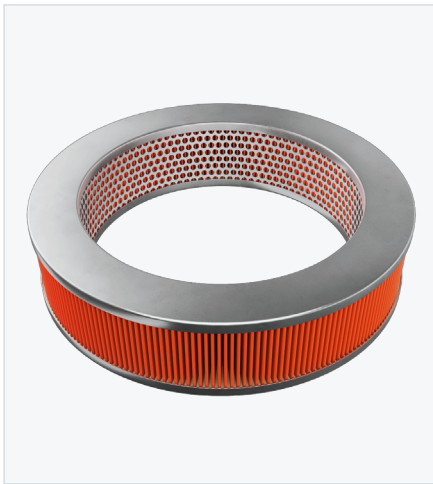

Radial air filters with bonded end caps



Cross-section of radial air filters with bonded end caps (top and bottom)

The material dynamically mixed in the mixing head is applied to the filter frames or end caps, either fully automatically via the CNC-controlled MK 825 PRO precision mixing head of the DM 502 dosing system, or manually by means of the MK 50 gun of the DM 70 COMPACT dosing machine. The excellent flow properties of FERMADUR adhesive sealants ensure full-surface bonding. The filter pack positioned in the filter frame is therefore optimally bonded and sealed on all sides. The adhesive sealants are cured at room temperature, which saves the expense of the annealing oven required by other methods.

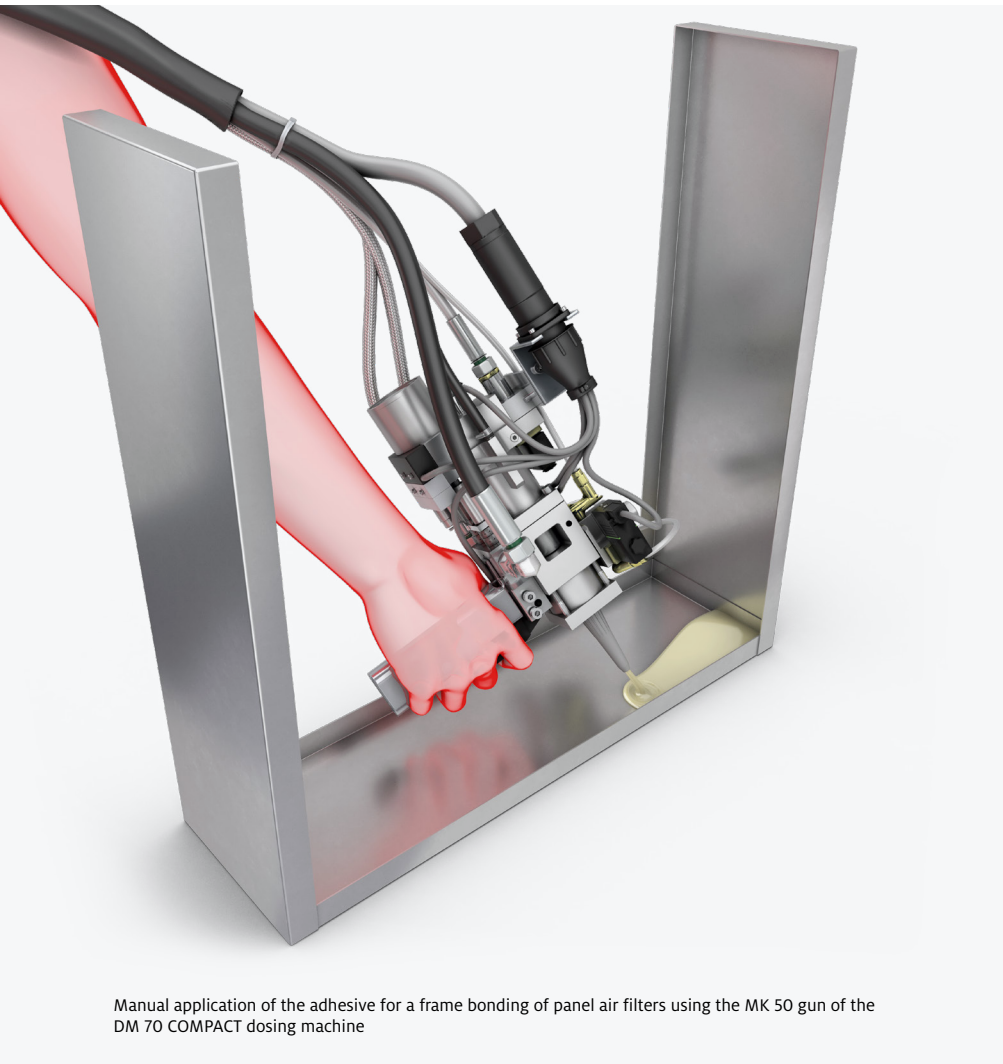

Manual application of the adhesive for a frame bonding of panel air filters using the MK 50 gun of the DM 70 COMPACT dosing machine

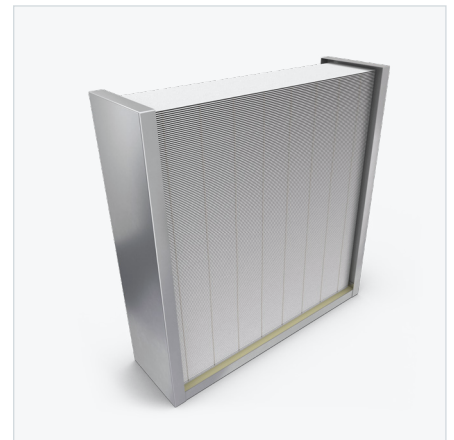

Bonding of the first three frame sides

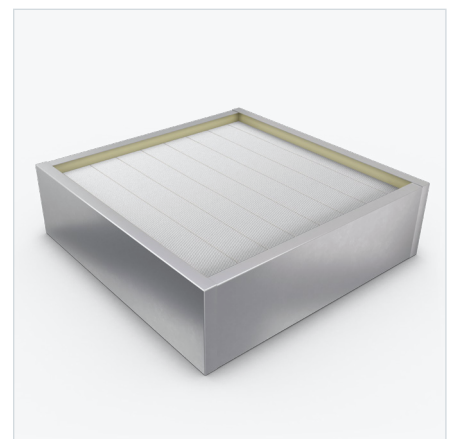

Filter pack bonded into the frame

Flexible and fully automatic – fully in line with your requirements

**DM 70 COMPACT mixing and dosing system for manual bonding
of filter packs into filter frames or end caps**

The DM 70 COMPACT mixing and dosing machine shown here is used to manually bond filter packs into the filter frames or to the end caps using the polyurethane-based adhesive sealant system FERMADUR A-196-9-VP1 or FERMADUR A-46D05-1-W, each of which is cured with the B component FERMADUR-B-N.

The dynamic mixing of the polymer reaction materials to be processed is carried out with the MK 50 dynamic mixing head. This process uses a dynamic agitator in the mixing chamber of the MK 50 to homogeneously mix two material components with one another in a specific mixing ratio, the A component and the crosslinker (B component).



Mixing and dosing machine DM 70 COMPACT with MK 50 mixing head on rolling chassis for manual material application

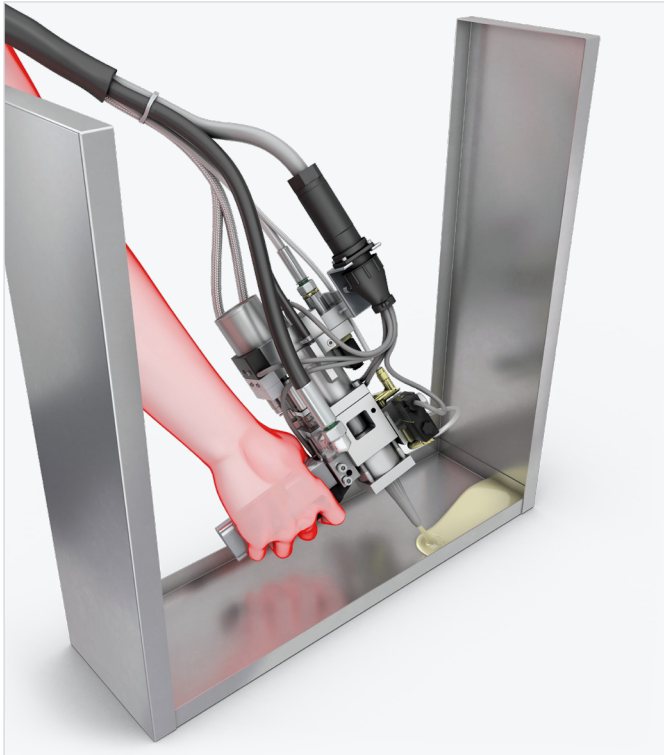

The dynamically mixed material is applied to the inside of the filter frame or to the end caps via the mixing head, which is designed in gun form. A full-surface bond is thus created thanks to the excellent flow properties of FERMADUR, with the filter pack optimally bonded and sealed into the frame on all sides.

Manual application of the adhesive for a frame bonding of panel air filters using the MK 50 gun of the DM 70 COMPACT dosing machine

The DM 70 COMPACT mixing and dosing machine is designed to enable you, the operator, to perform a wide variety of tasks easily and reliably. It is a mobile standalone system for manual operation and can be used to save space in your production facility. All machine components are mounted on a rolling chassis. It is operated via a 7" touchscreen. This allows variable adjustment of the material feed rate and mixing ratio. The simple accessibility of the machine enables care and maintenance work to be carried out quickly and easily.



The DM 70 COMPACT mixing and dosing machine without its front design cover, with precision gear pumps



The DM 70 COMPACT mixing and dosing machine with material pressure tanks (24 l or 44 l), equipped with minimum fill level sensors and an additional pressure tank for the mixing head cleaning agent

The image shows a close-up of a grey industrial machine head with the 'sonderhoff' logo in a teal color. A red, flexible, curved tube is being extruded from the bottom of the machine head. The machine has several screws and a textured adjustment ring.

sonderhoff

This is why you should use the FIPFG technology in your production process

- + Advantages of the Formed-In-Place Foam Gasket Technology**
- › Sealing standard in many industrial sectors
 - › Highly accurate material application controlled by contour robots
 - › Processing and full curing at room temperature
 - › Perfect coordination of the material system and dosing system
 - › Suitable for 2D and complex 3D part geometries
 - › More efficient use of materials compared to punched seals
 - › Cheaper compared to 2-C injection molding, as there are no tooling costs
 - › High degree of future viability, due to suitability for use in a wide variety of industries & applications



Advantages of our mixing and dosing machines

- › Combination of processes (bonding, foaming, caulking, potting)
- › High flexibility of the dosing system
- › Simple, intuitive operation
- › Automatic material preparation incl. handling
- › High dosing and repeat accuracy
- › Short machine downtimes and cycle times
- › Fine-cell foam structure due to dynamic mixing
- › Reproducible foam quality
- › Ecological high-pressure water rinsing
- › Easy maintenance



Advantages of our FIPFG foam gaskets

- › More cost-effective than compact systems due to lower foam density
- › Seamless seal / hardly visible coupling point
- › Compensation of component tolerances
- › Good resilience
- › Multiple compression and release processes possible
- › Broad range of properties / wide variety of recipes
- › Individually adaptable recipes
- › Good form fit to the component contour
- › Resistant to moisture, dust, temperature & media
- › Flame-retardant according to UL 94
- › IP classes up to IP 68 or NEMA 4 to 6 and NEMA 12
- › Special PU foam with low VOC emissions
- › Very fast reacting PU foam (Fast-Cure)

Perfectly coordinated solutions of material, machine and contract manufacturing

With its Sonderhoff brand, Henkel has not only acquired many years of experience in the manufacture of tailor-made two-component sealing systems and mixing and dosing machines, but also as a process expert for application-specific material application using the FIPFG (Formed-In-Place-Foam-Gasket) technology.

With the Sonderhoff portfolio, we offer you the advantages of a system provider from a single source and the solutions to meet your technical and commercial challenges.

With the dosing technology that is tailored to our sealing foams, we ensure efficient production processes in accordance with the requirements of fully automated series production.

If you would like to take advantage of all the benefits of the FIPFG technology for your production in a flexible, fast, uncomplicated manner and without having to make your own acquisition investments, we can provide expert sealing for your components at one of our contract manufacturing sites worldwide. There, the spectrum ranges from the sampling of prototypes and small batch series to production scale manufacturing.

The choice is yours! You can either decide in favor of our all-inclusive package, consisting of material, machine and contract manufacturing, supported by application advice, sampling and training or you can choose the individual solutions that suit you best. We combine our products and services from a single source in such a way that you receive the optimum solution for your requirements profile.

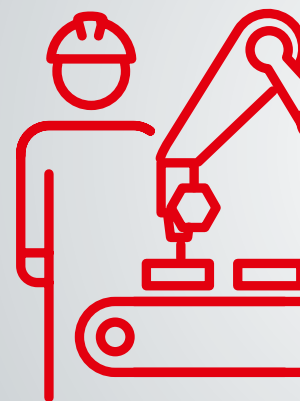

MANUFACT

Flexibility & Precision

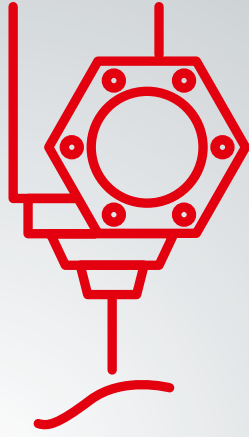

EQUIPMENT

Automation Solutions

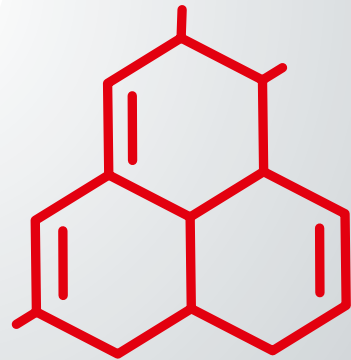

MATERIALS



MANUFACTURING

Customer-specific solutions – worldwide and for many industries

The Henkel specialists for the Sonderhoff portfolio
are available globally

KOLO, POLAND
External Subcontracting Location

DÜSSELDORF, GERMANY
Center of Expertise

ELGIN, ILLINOIS, USA
Regional Hub

RICHMOND (KANSAS CITY), USA
Regional Hub

DORNBIRN, AUSTRIA
Center of Expertise

BARCELONA, SPAIN
External Subcontracting Location

OGGIONO, ITALY
Regional Hub

INCHEON, KOREA
External Subcontracting Location

SHANGHAI, CHINA
Regional Hub

PUNE, INDIA
Regional Hub

PUNE, INDIA
External Subcontracting Location

SÃO PAULO, BRAZIL
External Subcontracting Location

Global presence



Every year, more than 300 million seals are manufactured in more than 50 countries using products from Henkel's Sonderhoff portfolio. At our Centers of Expertise and Regional Hubs, our specialists offer application engineering advice, e.g. selecting a suitable material system and sampling of your components, as well as project management for dosing systems and automation. You will receive training from us on how to use the FIPFG technology and we will support you with the selection of spare parts and a regular service offering. Furthermore, we will be pleased to take over parts of your production for you – from small to large series – at our subcontracting locations.

Sales staff at all other Henkel locations worldwide will also be happy to answer any questions and provide you with further information on our sealing, bonding, and potting solutions. We look forward to hearing from you.



Henkel AG & Co. KGaA

Henkelstraße 67
40589 Düsseldorf
Germany
Tel.: +49 211 797-0
Fax: +49 211 798 4008

www.henkel.com
www.sonderhoff.com

Get in contact with us



The description of the possible fields of use of our products as well as the technical data and values only have a general character and do not mean that a certain product can be used under all conditions in the respective field of use. In this respect, the stated field of use is not a binding specification or usage provision. Due to the great number of environment variables and their influences (e.g. temperature, test specimens, size, interaction with substrates, influence of machines, or the like) you as our customer must check whether the product is suitable for your specific field of use. We will be pleased to assist and advise you in this respect. Except as otherwise noted, all marks used above are trademarks and/or registered trademarks of Henkel and its affiliates in the U.S., Germany and elsewhere.

© 8.2024 Henkel AG & Co. KGaA. All rights reserved